



CITY COUNCIL/SUCCESSOR AGENCY/PUBLIC FINANCE AUTHORITY MEETING AGENDA

**April 2, 2026
6:00 PM**

The Mission of the City of Coalinga is to provide for the preservation of the community character by delivering quality, responsive City services, in an efficient and cost-effective manner, and to develop, encourage, and promote a diversified economic base in order to ensure the future financial stability of the City for its citizens.

Notice is hereby given that the City Council will hold a Meeting, on April 2, 2026 in the City Council Chambers located at 155 West Durian, Coalinga, CA. Persons with disabilities who may need assistance should contact the City Clerk at least 24 hours prior to this meeting at 935-1533 x113. Anyone interested in translation services should contact the City Clerk at least 24 hours prior to the meeting at 935-1533 x113. The Meeting will begin at 6:00 p.m. and the agenda will be as follows:

1. CALL TO ORDER

1. Pledge of Allegiance
2. Changes to the Agenda
3. Council's Approval of Agenda

2. AWARDS, PRESENTATIONS, APPOINTMENTS AND PROCLAMATIONS (NONE)

3. CITIZEN COMMENTS

This section of the agenda allows members of the public to address the City Council on any item within the jurisdiction of the Council. Members of the public, when recognized by the Mayor, should come forward to the lectern, identify themselves and use the microphone. Comments are normally limited to three (3) minutes. In accordance with State Open Meeting Laws, no action will be taken by the City Council this evening and all items will be referred to staff for follow up and a report.

Citizen Comments submitted in writing to the City Clerk by 5:00pm on the day of the City Council meeting shall be distributed to the City Council and included in the record,

however they will not be read.

4. PUBLIC HEARINGS (NONE)

5. CONSENT CALENDAR

1. Approve MINUTES - January 8, 2026
2. Check Register: 2/01/2026-2/28/2026
3. Authorization for the City Manager to Enter into an Agreement with RAD Studios for On-Call Photography Services
4. Introduce and Waive First Reading of Ordinance No. 878 Amending Chapter 6 of Title 7 of the Coalinga Municipal Code Relating to Summary Abatement of Public Nuisances
5. Adopt Resolution No. 4314 Approving a Budget Adjustment for Fire Department LED Sign
6. Consideration of Bid Award for Ramsey Park Splash Pad
7. Adopt Resolution No. 4315 in Support of the Better Roads, Safe Streets Transportation Measure
8. Adopt Resolution No. 4316 and Consideration of Approval of the Transfer of Appropriation No. 26-021 for a One Time Project of 2 Submersible Pumps for Sandalwood Lift Station for Fiscal Year 2025-2026
9. Authorization for the City Manager to Accept Quote for Street Sweeper Repair

6. ORDINANCE PRESENTATION, DISCUSSION AND POTENTIAL ACTION ITEMS

1. Authorization to Issue Request for Qualifications (RFQ) for Public Information Consulting Services
Sean Brewer, City Manager
2. Strategic Priorities Overview and FY 2026–2027 Budget Direction
Sean Brewer, City Manager

7. ANNOUNCEMENTS

1. City Manager's Announcements
2. Councilmembers' Announcements/Reports
3. City Treasurer's Announcements
4. Mayor's Announcements

8. FUTURE AGENDA ITEMS

9. CLOSED SESSION

1. CONFERENCE WITH LABOR NEGOTIATORS – Government Code 54957.6. CITY NEGOTIATORS: City Manager, Sean Brewer and City Attorney, Mario Zamora. EMPLOYEE (ORGANIZATIONS): General Employees and Coalinga Police Officers Association
2. REAL PROPERTY NEGOTIATIONS - Government Code Section 54956.8. CONFERENCE WITH REAL PROPERTY NEGOTIATORS. PROPERTY: APN: 070-070-42ST (Coalinga Airport) located in the City of Coalinga. CITY NEGOTIATORS: City Manager, Sean Brewer; and City Attorney, Mario Zamora.

NEGOTIATING PARTIES: Momentum Tactical, LLC. UNDER NEGOTIATION:
Price and Terms of Payment

3. CONFERENCE WITH LEGAL COUNSEL – ANTICIPATED LITIGATION
Significant exposure to litigation pursuant to Government Code Section 54956.9(d)(2)
or (3): (1 case)

10. CLOSED SESSION REPORT

Closed Session: A "Closed" or "Executive" Session of the City Council, Successor Agency, or Public Finance Authority may be held as required for items as follows: personnel matters; labor negotiations; security matters; providing instructions to real property negotiators; legal counsel regarding pending litigation; and protection of records exempt from public disclosure. Closed session will be held in the Administration Building at 155 W. Durian Avenue and any announcements or discussion will be held at the same location following Closed Session.

11. ADJOURNMENT

**STAFF REPORT - CITY COUNCIL/SUCCESSOR AGENCY/PUBLIC FINANCE
AUTHORITY**

Subject: Approve MINUTES - January 8, 2026
Meeting Date: Thursday, April 2, 2026
From: Sean Brewer, City Manager
Prepared by: Shannon Jensen, City Clerk

I. RECOMMENDATION:

II. BACKGROUND:

III. DISCUSSION:

IV. ALTERNATIVES:

V. FISCAL IMPACT:

ATTACHMENTS:

File Name	Description
<input type="checkbox"/> MINUTES_SPECIAL_For_Review___Approval_010826.pdf	Minutes - January 8, 2026

**SPECIAL
MINUTES
CITY COUNCIL/SUCCESSOR
AGENCY/PUBLIC FINANCE AUTHORITY
MEETING AGENDA
January 8, 2026**

1. CALL TO ORDER 6:00 PM

Council Members Present: Vosburg, Lowder, Schindler, Hedgecock

Others Present: City Manager Sean Brewer, Assistant City Attorney Nick Matoian, Assistant City Manager Jesse Barron, Chief of Police Jose Garza, Financial Services Director Mai Vang, City Treasurer Dawn Kahikina, Fire Chief Greg DuPuis, Administrative Analyst Mercedes Garcia, and City Clerk Shannon Jensen

Council Members Absent: Ramirez

Others Absent: None

Changes to the Agenda: City Manager Sean Brewer announced the following Changes to the Agenda:

1. Table Item No. 5.5 for future meeting.

*Motion by Hedgecock, Second by Schindler to Approve the Agenda for the Special meeting of January 8, 2026. Motion **Approved** by 4/0 Roll-Call Majority Vote. (Ramirez – Absent)*

2. AWARDS, PRESENTATIONS, APPOINTMENTS AND PROCLAMATIONS

1. Receive Presentation – Sports Car Club of America (SCCA) Autocross & Rallycross Events at Coalinga Municipal Airport

Brandon Briggs presented information regarding proposed Sports Car Club of America (SCCA) Autocross and Rallycross events at the Coalinga Municipal Airport.

By consensus, the City Council directed staff to continue conversations and explore opportunities to facilitate these events at the airport.

2. Recognizing Councilmember Lonnie Hedgecock's Service on the City Council

Mayor Vosburg presented a plaque to Councilman Hedgecock in recognition of his dedicated service and contributions to the City Council.

Councilman Hedgecock offered remarks thanking staff and fellow Councilmembers for their support and collaboration throughout his tenure.

3. CITIZEN COMMENTS

The following individual(s) spoke under Citizen Comments:

None

The following individual(s) submitted written comment(s):

Robert Smith - 2

4. PUBLIC HEARINGS

None

5. CONSENT CALENDAR

1. Approve MINUTES – November 13, 2025
2. Check Register: 11/01/2025 – 11/30/2025
3. Authorize City Manager to Approve and Sign the Engagement Letter with Price Paige & Company for Professional Services to Revamp the Chart of Accounts
4. State Route 33 Rehabilitation and Complete Streets Project Update – Future Agenda Item – Councilman Ramirez
5. Adopt Resolution No. 4303 Approving Water Conveyance Agreement with Gladstone California Water LP for Westlands Source Water to be Conveyed in January and February

*Item No. 5.5 was **Tabled** during Changes to the Agenda.*

6. Authorization to Issue a Request for Qualifications (RFQ) for On-Call General Photography Services
7. Authorization to Advertise a Request for Qualifications (RFQ) for Videography and Photography Services for the 2026 Wings Over the Westside Airshow
8. Introduce and Waive the First Reading of Ordinance No. 877 – Authorizing the City Manager to Execute City Instruments Pursuant to California Government Code Section 40602

*Mayor Pro-Tem Schindler **Pulled** Item No. 5.8 for Discussion.*

Mayor Pro-Tem Schindler supported narrowing the scope of the ordinance before it returns for the second reading.

9. Adopt Resolution No. SA-350 Recognized Obligation Payment Schedule 26-27 for the July 2026 through June 2027 Period and the Successor Agency Administrative Budget for Fiscal Year 2026-27
10. Adopt Resolution No 4304 Modifying the Special Terms of Sewer Rates to Allow Some Exemptions for Sewer Charges Applied to Metered Potable Water that is Not Discharged into the City's Sewer System
11. Approval of the Appointment of Mayor Pro-Tem Roger Schindler as Alternate to the Fresno Council of Governments Policy Board
12. Authorize City Manager to Execute Task Order with the City Engineer for Design Engineering for Segment 7, 8, and 9c of the Coalinga Multi-Trail System Funded by the Active Transportation Program
13. Authorize the City Manager to Execute Task Order with the City Engineer for Design Engineering for Resurfacing Phase 3 Project
14. Approve Service Agreement with RSG Solutions to Prepare the FY2024-25 Housing Successor Agency Expenditure Report
15. Adopt Resolution No. 4306 Accepting Real Property Easement related to the Multi-Use Trail Segments 1e, 2, 13, and 14 Easement Acquisition (APN 071-020-58S)

*Motion by Schindler, Second by Lowder to Approve Consent Calendar Item Nos. 5.1 through 5.4 and 5.6 through 5.15 with changes to Item No. 5.8 to narrow the scope of Ordinance No. 877 prior to bringing it back for the second reading. **Approved** by 4/0 Roll-Call Majority Vote. (Ramirez – Absent)*

6. ORDINANCE PRESENTATION, DISCUSSION AND POTENTIAL ACTION ITEMS

1. Presentation and Discussion of Proposed Cannabis Ordinance Overhaul (Repeal and Replace Framework)
Sean Brewer, City Manager

City Manager Sean Brewer provided a brief overview of the item and introduced David Kaufman and Kyle Tankard of SCI Consulting Group who presented a proposed overhaul of the City's current cannabis ordinance.

By consensus, the City Council directed staff to bring back a draft ordinance for their consideration.

2. City Council Adoption of Resolution No. 4305 Establishing a Gas Enterprise Capital Improvement and Rate Stabilization Fund; Adopt Policies Governing Both Funds; and Amend the City's Gas Purchase Policy to Incorporate Rate Stabilization and Capital Improvement
Dan Bergmann, IGS and Sean Brewer, City Manager

Dan Bergmann of IGService provided a presentation regarding Resolution No. 4305 establishing a Gas Enterprise Capital Improvement and Rate Stabilization Fund, adoption of policies governing both funds, and amendments to the City's Gas Purchase Policy.

City Manager Sean Brewer provided additional context, noting the item was a continuation of prior gas rate discussions.

*Motion by Schindler, Second by Hedgecock to Adopt Resolution No. 4305 with revisions to Section 7 to reflect a \$500,000 funding level for the Rate Stabilization Fund. **Approved** by a 4/0 Roll-Call Majority Vote. (Ramirez – Absent)*

3. Presentation, Discussion and Potential Action – Clean City Initiative – Code Enforcement and Abatement Strategy

Jesse Barron, Assistant City Manager

Assistant City Manager Jesse Barron provided an overview of the item.

By consensus, the City Council directed staff to proceed with implementation of the Clean City Initiative, including prioritizing abatement of burned and unsafe structures, enhancing code enforcement efforts, and initiating community outreach. Council further directed staff to return with cost estimates for abatement activities for Council's consideration approval prior to undertaking such actions, evaluate options for earlier lien placement on properties, and explore alternative outreach methods, including cost-effective mailers and text notification options.

Council also supported continued coordination with Mid Valley Disposal and community partners to explore a community cleanup event and additional strategies to address illegal dumping.

4. Provide Direction to Staff regarding the Submission of Regional Priorities to Fresno Council of Governments (Fresno COG) for Consideration as Part of the 2026 One Voice D.C. Advocacy Trip
Sean Brewer, City Manager

City Manager Sean Brewer provided a brief overview of the item.

By consensus, the City Council directed staff to proceed with submitting priority projects consistent with prior year submissions, with a focus on airport-related projects, and to coordinate with staff to provide supporting documentation where feasible.

5. Discussion of Potential Washington D.C. Trip for Federal Earmark Advocacy with the City's Federal Lobbyists

Sean Brewer, City Manager

City Manager Sean Brewer provided a brief overview of the item.

By consensus, Council directed staff to solicit availability from individual Councilmembers to determine preferred travel dates and potential attendance, and to report back for further coordination.

6. Consideration of Establishing an Ad Hoc Community Outreach and Interagency Communication Committee – Future Agenda Item – Mayor Vosburg

Sean Brewer, City Manager

City Manager Sean Brewer provided a brief overview of the item.

By consensus, Council directed staff to bring back a draft policy establishing the Ad Hoc Committee for Council consideration at a future meeting, and to defer selection of committee members until the full Council is seated.

7. Review Applications and Possible Appointment for City Council Seat to be Vacated by Councilman Hedgecock (District 5)

Mario Zamora, City Attorney

City Manager Sean Brewer provided an overview of the item, stating that this was a Future Agenda Item requested by Mayor Pro-Tem Schinder.

By consensus, the City Council directed staff to evaluate options for providing front counter services on Fridays and to return with information regarding staffing models, operational impacts, service levels, and associated costs, including whether limited or rotating coverage could meet community needs.

City Attorney Mario Zamora provided a brief overview of the process for a possible appointment for the City Council seat being vacated by Councilman Hedgecock (District 5) as outlined in the Council Code of Conduct. Swearing in of a newly appointed Councilmember shall take place at the next City Council meeting.

Candidate Ron Ramsey introduced himself and stated his interest in serving on the City Council.

Candidate Pedro Garcia introduced himself and stated his interest in serving on the City Council.

Candidate Abel Arroyo introduced himself and stated his interest in serving on the City Council.

Councilman Hedgecock nominated Abel Arroyo for appointment to the District 5 seat.

Councilman Lowder nominated Abel Arroyo for appointment to the District 5 seat.

Mayor Pro-Tem Schindler nominated Abel Arroyo for appointment to the District 5 seat.

Mayor Vosburg nominated Pedro Garcia for appointment to the District 5 seat.

The City Clerk took Roll-Call Vote for nominations.

*Council approved the appointment of **Abel Arroyo** to serve as the District 5 City Council representative. **Approved** by a 4/0 Roll-Call Majority Vote. (Ramirez – Absent)*

7. ANNOUNCEMENTS

City Manager's Announcements:

City Manager Sean Brewer announced that a Special City Council Meeting is being scheduled for January 20, 2026, subject to confirmation of availability. He also announced that a Brown Act training is planned for

February 5, 2026, to be held prior to the regular City Council meeting, with an anticipated start time of 5:00 PM, and will include participation from the Planning Commission.

Council Member's Announcements:

Councilmembers expressed appreciation for Councilmember Lonnie Hedgecock's service to the City and wished him well in his future endeavors.

Councilmember Hedgecock provided remarks thanking the City Council, City staff, and the community for their support during his tenure, and expressed appreciation for the opportunity to serve the City of Coalinga.

City Treasure Dawn Kahikina stated she had no announcements to report.

Mayor's Announcements:

Mayor Nathan Vosburg provided an update on Fresno Council of Governments (COG) discussions related to Measure C, noting that an agreement was not reached between the cities and the County and that the measure, as proposed, will not move forward. He stated that alternative measures may be brought forward by other groups in the future and that the City will continue to monitor developments and provide updates as appropriate.

8. FUTURE AGENDA ITEMS

Councilman Hedgecock requested a traffic study for the addition of speed bumps or stop signs for Sacramento Street between Forest Avenue and Warthan Street, to evaluate speeding concerns and potential traffic-calming measures.

Councilman Ramirez requested an update on upcoming Caltrans road work activities, including anticipated timelines and scope of work.

Mayor Vosburg requested deployment of the City's speed radar trailer along Jayne Avenue, particularly near the Phelps Avenue intersection, to address speeding concerns as vehicles approach the City, siting a potential need to reduce the speed limit in the future.

Mayor Pro-Tem Schindler requested staff to explore opportunities to recognize America's 250th Anniversary on the City's digital sign.

Councilman Lowder requested staff to provide an update on the proposed food court project, including anticipated timeline and methods to promote community awareness and engagement.

Mayor Vosburg requested increased promotion of the City's mobile application and exploration of additional outreach tools, including the use of QR codes.

Mayor Vosburg requested a Future Agenda Item to provide an update on the City's social media and public outreach efforts, to be presented by the City's new Public Outreach Coordinator Jessenia Medina.

9. CLOSED SESSION

1. CONFERENCE WITH LABOR NEGOTIATORS – Government Code Section 54957.6. CITY NEGOTIATORS: City Manager, Sean Brewer and City Attorney, Mario Zamora. EMPLOYEE (ORGANIZATION); General Employees
2. REAL PROPERTY NEGOTIATIONS – Government Code Section 54956.8. CONFERENCE WITH REAL PROPERTY NEGOTIATORS. PROPERTY(S): APN: 070-070-42ST (Coalinga Airport) located in the City of Coalinga. CITY NEGOTIATORS: City Manager, Sean Brewer and City Attorney, Mario Zamora. NEGOTIATING PARTIES: Momentum Tactical, LLC. UNDER NEGOTIATION: Price and Terms of Payment
3. CONFERENCE WITH LABOR NEGOTIATORS – Government Code 54957.6. CITY NEGOTIATORS: City Manager, Sean Brewer and City Attorney, Mario Zamora. EMPLOYEE (ORGANIZATION): Police Officer Association
4. CONFERENCE WITH LEGAL COUNSEL – Potential Litigation – Significant Exposure to Litigation Pursuant to Government Code Section 54956.9(b) – 1 Case

10. CLOSED SESSION REPORT

No reportable action was taken during Closed Session.

11. ADJOURNMENT 9:44 PM

APPROVED:

Nathan Vosburg, Mayor

ATTEST:

Shannon Jensen, City Clerk

Date

Dear Mayor Vosburg and Council members,

I am writing as both a citizen of our city and a current employee covered under the General Employees Memorandum of Understanding (MOU). Although I am no longer a registered union member following recent changes in union leadership, I feel compelled to share my perspective on the proposed cost-of-living adjustment (COLA) for the General Employees Union, which I understand is scheduled for discussion in closed session at this week's council meeting.

As the past President of the Union, I have firsthand experience with labor negotiations and appreciate the efforts of previous Councils in securing fair COLAs for our employees. I want to sincerely thank those former Council members for the adjustments we received, which helped address years of wage stagnation prior to 2019—a fact that many newer union members may not fully appreciate.

That said, I am concerned about the current approach to negotiations. While I fully recognize that negotiations are an essential part of the process, I struggle to understand the rationale for pursuing such a significant adjustment at this stage, especially with the actual collective bargaining process set to begin this spring. Thank you for your time and consideration of this citizen comment. I trust in your judgment to navigate these negotiations fairly and in the best interest of our community.

Sincerely,
Robert Smith

Dear Mayor Vosburg and Members of the Coalinga City Council,

I am writing as a concerned citizen and long-time resident of Coalinga to urge the City Council to immediately set a firm, proactive campaign for extending the sunset date of Measure J, our 1% local sales tax for general city services, primarily public safety.

I understand this issue is likely already on the Council's radar, especially following the disappointing failure of the renewal measure on the November 2024 ballot. That setback makes it even more critical for the City to work harder and smarter this time. With the next viable election opportunity likely in November 2028, now is the time to begin building broad community support on this sensitive tax issue.

I respectfully ask that the City Council and the affected employee unions and associations collaborate closely to present a clear, transparent picture to the voters of exactly what the 1% tax has provided since it took effect in April 2019, and what essential services will be at serious risk if it is allowed to sunset.

Many current Council members were not serving before Measure J passed, but as citizens of Coalinga at the time, you will remember the challenging state of our City's finances. Prior to 2019, we simply did not have the resources for key positions and adequate staffing. We lacked a dedicated animal control officer, a code enforcement officer, and sufficient personnel levels in both our Fire and Police departments. Measure J revenue has helped change that, enabling the City to hire and retain essential staff, improve public safety response times, and maintain basic services that keep our community safe and livable.

I recognize there is understandable reluctance to place another tax measure on the ballot, and I myself am usually opposed to most new taxes. However, I strongly believe we cannot afford to return to the pre-2019 predicament of understaffed departments and limited services. Allowing the tax to expire would almost certainly force painful cuts that would impact every resident.

If the City and its partners begin planning and outreach early, there is a real opportunity to regain voter approval. I strongly encourage you to:

- Develop and publicize a clear, updated priorities list showing how future Measure J funds would be allocated.
- Highlight specific achievements made possible by the tax since 2019, such as increased staffing, improved response capabilities, new equipment, and enhanced community safety programs.
- Engage the community through town halls, informational mailers, and open meetings to build understanding and support.

By starting this effort now with transparency and collaboration, I believe we can make a compelling case to voters that continuing this modest tax is a worthwhile investment in Coalinga's future.

Thank you for your service to our community and for considering this request. I am happy to discuss these ideas further or assist in any way I can. I look forward to seeing decisive action to protect and strengthen the services our residents depend on.

Sincerely,

Robert Smith

**STAFF REPORT - CITY COUNCIL/SUCCESSOR AGENCY/PUBLIC FINANCE
AUTHORITY**

Subject: Check Register: 2/01/2026-2/28/2026
Meeting Date: Thursday, April 2, 2026
From: Sean Brewer, City Manager
Prepared by: Yasmin Gonzalez, Financial Services Supervisor

I. RECOMMENDATION:

II. BACKGROUND:

III. DISCUSSION:

IV. ALTERNATIVES:

V. FISCAL IMPACT:

ATTACHMENTS:

File Name	Description
<input type="checkbox"/> 2026-02_Check_Register_Cover_Sheet_for_Council.pdf	Check Register Cover Sheet - February 2026
<input type="checkbox"/> 2026-02_Check_Register.pdf	Check Register - February 2026



CITY OF COALINGA

The Sunny Side of the Valley

CHECK REGISTER

COUNCIL MEETING OF
Thursday, April 2, 2026

EXPENSES: 2/1/2026 through 2/28/2026

ACCOUNTS PAYABLE:

Month Ending: 2/28/2026 Registers: # 80525 - # 80764 \$ 1,403,313.98

PAYROLL:

Pay Period Ending: 2/8/2026 Payroll Check # 19072-19074 \$ 528.79
Pay Date: 2/13/2026 Direct Deposit \$ 249,594.19
Payroll Total: \$ 250,122.98

Pay Period Ending: 2/22/2026 Payroll Check # 19076-19080 \$ 712.21
Pay Date: 2/27/2026 Direct Deposit \$ 241,175.30
Correction: 2/27/2026 Payroll Check #19075 \$ 535.62
Payroll Total: \$ 242,423.13

TOTAL CHECK REGISTERS THROUGH: 2/28/26 \$ 1,895,860.09



City of Coalinga

Check Register

By Payment Number

Payment Dates 2/1/2026 - 2/28/2026

Payment Number	Payment Date Payable Number	Vendor # Description	Vendor Name	Account Number	Payment Amount Item Amount
80525	2/5/2026	02388	AMAZON CAPITAL SERVICES., INC		1,937.28
	1DNC-WLPD-4FR6	1/26 PD Road Flares/ Equipment		101-413-70101	1,937.28
80526	2/5/2026	02386	American Office Solutions, LLC		1,946.33
	26193	2/26 FD Data Backup		101-416-88040	165.08
	26194	2/26 PD Computer Programing		101-413-88040	1,781.25
80527	2/5/2026	02978	Angel Armor, LLC		773.50
	INV16975	2/26 PD Armor/ Uniforms		101-413-70101	773.50
80528	2/5/2026	1078	AT&T		1,540.80
	0014533	12/25 PD Telephone/Internet (125125740)		101-413-72030	770.40
	0014540	1/26 PD Telephone (125125740)		101-413-72030	770.40
80529	2/5/2026	02080	AT&T 4050		1,096.10
	000024667766	1/26 PD Phone Svcs 12/13-1/12/26 (9391064050)		101-413-72030	1,096.10
80530	2/5/2026	02056	AT&T 4711		285.94
	000024667904	1/26 PD DOJ Phone 12/13/25-1/12/26 (9391064711)		101-413-72030	285.94
80531	2/5/2026	02082	AutoZone, Inc.		174.59
	05919480385	1/26 FD M251 Coolant		117-416-84060	54.44
	0591956549	1/26 PD Water Pump		101-413-84060	120.15
80532	2/5/2026	02132	Badger Meter, Inc.		2,398.13
	80225680	1/26 Cellular Service Meter Jan 2026		501-508-98054	2,398.13
80533	2/5/2026	1112	BILLINGSLEY TIRE SERVICE		482.68
	CLG-310229	1/26 WWP Tire Repair		503-520-84060	30.00
	CLG-310782	1/26 PD Tire Repair		101-413-84060	422.68
	CLG-310838	1/26 PW Tire Repair #72		501-508-84060	10.00
	CLG-310838	1/26 PW Tire Repair #72		502-510-84060	10.00
CLG-310838	1/26 PW Tire Repair #72		503-521-84060	10.00	
80534	2/5/2026	03040	BLUETRITON BRANDS INC		130.92
	06A8730275832	2/26 City Hall Water Delivery		101-432-72010	130.92
80535	2/5/2026	02020	Boot Barn		200.00
	INV00558424	1/26 WWP J. Echeagaray Boots		503-520-62081	200.00
80536	2/5/2026	02363	BRADY KAISER		299.00
	TR21221	2/26 B. Kaiser Meal Advance		101-413-86010	299.00
80537	2/5/2026	02504	Brian Corley		16,045.55
	25-100702	1/26 WWP New Pressure Transmitter		501-503-84020	10,297.12
	26-011601	1/26 WWP Troubleshoot Hydro VFD		501-503-84020	944.10
	26-012201	1/26 WWP New Batteries/ Solar Panel		501-503-84020	2,344.73
	26-012301	1/26 WWP Calibrate Ammonia Sensors		501-503-84020	2,459.60
80538	2/5/2026	02296	BSK Associates		2,802.25
	AI25615	1/26 WWP Outside Lab Work		501-503-88081	1,645.00
	AI25615	1/26 WWP Outside Lab Work		503-520-88080	120.00
	AI33384	1/26 WWP Outside Lab Work		501-503-88081	1,037.25
80539	2/5/2026	1133	Bureau of Reclamation		28,014.24
	BOR-APR2026	April 2026 Estimate		501-503-80010	23,619.00
	BOR-APR2026	January 2026 Adjustment		501-503-80010	-1,167.84

Check Register

Payment Dates: 2/1/2026 - 2/28/2026

Payment Number	Payment Date Payable Number	Vendor # Description	Vendor Name	Account Number	Payment Amount Item Amount
	BOR-APR2026	January 2026 Restoration		501-503-80010	5,563.08
80540	2/5/2026	1142	California Business Machines		434.95
	566751	12/25 Copier Maint. Agreement	COUNCIL	101-401-84010	7.41
	566751	12/25 Copier Maint. Agreement	CD	101-404-84010	6.51
	566751	12/25 Copier Maint. Agreement	BLDG	101-404-84010	1.46
	566751	12/25 Copier Maint. Agreement	CITY MGR	101-405-84010	27.49
	566751	12/25 Copier Maint. Agreement	FINANCE	101-406-84010	0.14
	566751	12/25 Copier Maint. Agreement	FIN	101-406-84010	4.26
	566751	12/25 Copier Maint. Agreement	HR	101-408-84010	46.07
	566751	12/25 Copier Maint. Agreement	PD	101-413-84010	80.18
	566751	12/25 Copier Maint. Agreement	FD	101-416-84010	29.72
	566751	12/25 Copier Maint. Agreement	HR	107-422-84010	1.81
	566751	12/25 Copier Maint. Agreement	HR	117-416-84010	10.84
	566751	12/25 Copier Maint. Agreement	FIN	501-406-84010	56.76
	566751	12/25 Copier Maint. Agreement	HR	501-406-84010	3.61
	566751	12/25 Copier Maint. Agreement	FINANCE	501-406-84010	1.90
	566751	12/25 Copier Maint. Agreement	HR	501-503-84010	5.42
	566751	12/25 Copier Maint. Agreement	WP	501-503-84010	10.39
	566751	12/25 Copier Maint. Agreement	WP	501-503-84010	5.26
	566751	12/25 Copier Maint. Agreement	HR	501-508-84010	6.32
	566751	12/25 Copier Maint. Agreement	HR	502-406-84010	3.61
	566751	12/25 Copier Maint. Agreement	FIN	502-406-84010	49.67
	566751	12/25 Copier Maint. Agreement	FINANCE	502-406-84010	1.66
	566751	12/25 Copier Maint. Agreement	HR	502-510-84010	6.32
	566751	12/25 Copier Maint. Agreement	FINANCE	503-406-84010	0.95
	566751	12/25 Copier Maint. Agreement	FIN	503-406-84010	28.38
	566751	12/25 Copier Maint. Agreement	HR	503-406-84010	1.35
	566751	12/25 Copier Maint. Agreement	WWP	503-520-84010	29.37
	566751	12/25 Copier Maint. Agreement	WWP	503-520-84010	0.19
	566751	12/25 Copier Maint. Agreement	HR	503-520-84010	2.71
	566751	12/25 Copier Maint. Agreement	HR	503-521-84010	0.90
	566751	12/25 Copier Maint. Agreement	FINANCE	504-406-84010	0.10
	566751	12/25 Copier Maint. Agreement	FIN	504-406-84010	2.84
	566751	12/25 Copier Maint. Agreement	HR	504-406-84010	0.45
	566751	12/25 Copier Maint. Agreement	HR	820-610-84010	0.90
80543	2/5/2026	02889	CAL-LINE EQUIPMENT INC		1,032.31
	04029603	1/26 PW Chipper Pump		101-440-84060	516.15
	04029603	1/26 PW Chipper Pump		107-422-84060	516.16
80544	2/5/2026	1175	Carus Corporations		19,104.05
	SLS10125236	1/26 WWP Chemical Permanganate		501-503-70400	19,104.05
80545	2/5/2026	02594	CINTAS CORPORATION #3		561.07
	4256930005	1/26 BLDG Employee Uniforms/Sanitary Supplies/M		101-404-70100	13.06
	4256930005	1/26 SC Employee Uniforms/Sanitary Supplies/Mats		101-431-70100	45.37
	4256930005	1/26 ADM Employee Uniforms/Sanitary Supplies/M		101-432-84030	72.71
	4256930005	1/26 MG Employee Uniforms/Sanitary Supplies/Mat		101-440-70100	85.76
	4256930005	1/26 GT Employee Uniforms/Sanitary Supplies/Mats		107-422-70100	52.81
	4256930005	1/26 WTP Employee Uniforms/Sanitary Supplies/Ma		501-503-70100	58.89
	4256930005	1/26 WD Employee Uniforms/Sanitary Supplies/Mat		501-508-70100	52.81
	4256930005	1/26 MR Employee Uniforms/Sanitary Supplies/Mat		501-508-70100	23.34
	4256930005	1/26 MR Employee Uniforms Sanitary Supplies		502-510-70100	23.34
	4256930005	1/26 GE Employee Uniforms/Sanitary Supplies/Mats		502-510-70100	52.81
	4256930005	1/26 WWTP Employee Uniforms/Sanitary Supplies/		503-520-70100	27.36
	4256930005	1/26 WWC Employee Uniforms/Sanitary Supplies/M		503-521-70100	52.81
80546	2/5/2026	02598	CINTAS CORPORATION NO. 2		646.38
	5309462309	1/26 PW First Aid Kit Refill		101-413-88100	90.11
	5309462309	1/26 PW First Aid Kit Refill		101-432-84030	8.21

Check Register

Payment Dates: 2/1/2026 - 2/28/2026

Payment Number	Payment Date Payable Number	Vendor # Description	Vendor Name	Account Number	Payment Amount Item Amount
	5309462309	1/26 PW First Aid Kit Refill		503-521-70440	119.64
	5309462310	1/26 PW First Aid Kit Refill		101-431-70150	77.35
	5312670603	1/26 WWP First Aid Kit Refill		501-503-84072	54.98
	5312670603	1/26 WWP First Aid Kit Refill		503-520-84073	54.98
	5313928403	1/26 PW First Aid Kit Refill		101-413-88100	112.53
	5313928403	1/26 PW First Aid Kit Refill		101-432-84030	8.21
	5313928403	1/26 PW First Aid Kit Refill		503-521-70440	120.37
80547	2/5/2026	1224	COALINGA HARDWARE		638.53
	838899	1/26 WWP Anchor Bolts		501-503-70140	47.35
	838915	1/26 WWP Epoxy Paste		501-503-70140	78.66
	838917	1/26 WWP Charging Cable		501-503-70140	35.19
	839009	1/26 WWP Sandpaper/ Body Filler		501-503-70140	87.51
	839016	1/26 WWP Eye Screws		501-503-70140	5.98
	839028	1/26 WWP Fiber Repair Kit		501-503-70140	18.62
	839270	1/26 PW Sprayer		501-508-70060	28.98
	839370	1/26 PW Sewer Repair Supplies		503-521-70140	151.46
	839395	2/26 Airport Lighting		101-435-84030	4.75
	839412	1/26 Airport Transfueler Wiring		101-432-84030	180.03
80548	2/5/2026	02944	County of Alameda		940.00
	0014536	2/26 Radar Operator Course B. Kaiser TR21221		101-413-86010	470.00
	0014536	2/26 Radar Operator Course J. Vega TR21222		101-413-86010	470.00
80549	2/5/2026	02575	Damien Sparks		279.00
	TR21223	2/26 PD Meal Advance D. Sparks		101-413-86010	279.00
80550	2/5/2026	02787	Data Ticket, Inc.		150.00
	188643	1/26 PD Data Ticket		101-413-88100	150.00
80551	2/5/2026	1271	DataProse, Inc.		4,151.74
	DP2506189	11/25 Search & Viewbill Monthly Service Fee		501-406-70040	30.00
	DP2506189	11/25 Search & Viewbill Monthly Service Fee		502-406-70040	26.25
	DP2506189	11/25 Search & Viewbill Monthly Service Fee		503-406-70040	17.25
	DP2506189	11/25 Search & Viewbill Monthly Service Fee		504-406-70040	1.50
	DP2600486	12/25 Postage Used		501-406-70030	1,062.16
	DP2600486	12/25 Regular Bills		501-406-70040	465.47
	DP2600486	Search & Viewbill		501-406-70040	29.05
	DP2600486	12/25 NCOALINK		501-406-70040	5.40
	DP2600486	InvoiceCloud		501-406-70040	38.61
	DP2600486	Monthly Service Fee		501-406-70040	30.00
	DP2600486	12/25 Postage Used		502-406-70030	929.39
	DP2600486	12/25 Regular Bills		502-406-70040	407.28
	DP2600486	InvoiceCloud		502-406-70040	33.79
	DP2600486	Search & Viewbill		502-406-70040	25.42
	DP2600486	Monthly Service Fee		502-406-70040	26.65
	DP2600486	12/25 NCOALINK		502-406-70040	4.73
	DP2600486	12/25 Postage Used		503-406-70030	610.74
	DP2600486	Monthly Service Fee		503-406-70040	17.25
	DP2600486	12/25 Regular Bills		503-406-70040	267.64
	DP2600486	12/25 NCOALINK		503-406-70040	3.11
	DP2600486	Search & Viewbill		503-406-70040	16.71
	DP2600486	InvoiceCloud		503-406-70040	22.60
	DP2600486	12/25 Postage Used		504-406-70030	53.11
	DP2600486	InvoiceCloud		504-406-70040	1.97
	DP2600486	Search & Viewbill		504-406-70040	1.45
	DP2600486	Monthly Service Fee		504-406-70040	0.74
	DP2600486	12/25 Regular Bills		504-406-70040	23.27
	DP2600486	12/25 NCOALINK		504-406-70040	0.20

Check Register

Payment Dates: 2/1/2026 - 2/28/2026

Payment Number	Payment Date Payable Number	Vendor # Description	Vendor Name	Account Number	Payment Amount Item Amount
80553	2/5/2026	1303	Dooley Enterprises, Inc.		15,359.72
	71247	1/26 PD Ammo		105-413-98041	9,998.76
	71248	1/26 PD Ammo		105-413-98041	5,360.96
80554	2/5/2026	03115	EDUARDO GUERRERO		380.00
	0014401	1/26 Employee Appreciation Dinner Photobooth		101-401-88220	380.00
80555	2/5/2026	02289	Elecsys International, LLC		156.00
	SIP-E226908	1/26 Rectfifer Cell Data Jan 2026		502-510-72030	156.00
80556	2/5/2026	1349	Emergency Vehicle Group, Inc.		266.17
	46111	1/26 FD M251 GPS Plate		117-416-84060	266.17
80557	2/5/2026	02379	GEOTAB USA, INC.		290.00
	IN471731	1/26 PW GPS for UTV's & Sweeper		101-440-88100	59.25
	IN471731	1/26 PW GPS for UTV's & Sweeper		504-535-88100	39.50
	IN471756	1/26 FD January Geotab		101-416-84060	191.25
80558	2/5/2026	02192	GIMME LOVE ANIMAL SHELTER		3,472.00
	0014535	2/26 Councilman Schindler Donation Feb-2026		101-415-88100	450.00
	103	1/26 PD Jan 2026 Shelter Services		101-415-88100	3,022.00
80559	2/5/2026	1439	Government Staffing Services, Inc.		3,769.50
	130653	1/26 MuniTemps HR Generalist C. Gallow		101-408-60010	881.79
	130653	1/26 MuniTemps HR Generalist C. Gallow		107-422-60010	30.94
	130653	1/26 MuniTemps HR Generalist C. Gallow		117-416-60010	201.11
	130653	1/26 MuniTemps HR Generalist C. Gallow		501-406-60010	30.94
	130653	1/26 MuniTemps HR Generalist C. Gallow		501-503-60010	92.82
	130653	1/26 MuniTemps HR Generalist C. Gallow		501-508-60010	77.35
	130653	1/26 MuniTemps HR Generalist C. Gallow		502-406-60010	30.94
	130653	1/26 MuniTemps HR Generalist C. Gallow		502-510-60010	77.35
	130653	1/26 MuniTemps HR Generalist C. Gallow		503-406-60010	23.21
	130653	1/26 MuniTemps HR Generalist C. Gallow		503-520-60010	46.41
	130653	1/26 MuniTemps HR Generalist C. Gallow		503-521-60010	23.21
	130653	1/26 MuniTemps HR Generalist C. Gallow		504-535-60010	15.47
	130653	1/26 MuniTemps HR Generalist C. Gallow		820-610-60010	15.46
	130659	01/26 MuniTemps- HR Generalist C. Gallow		101-408-60010	1,266.83
	130659	01/26 MuniTemps- HR Generalist C. Gallow		107-422-60010	44.45
	130659	01/26 MuniTemps- HR Generalist C. Gallow		117-416-60010	288.93
	130659	01/26 MuniTemps- HR Generalist C. Gallow		501-406-60010	44.45
	130659	01/26 MuniTemps- HR Generalist C. Gallow		501-503-60010	133.35
	130659	01/26 MuniTemps- HR Generalist C. Gallow		501-508-60010	111.13
	130659	01/26 MuniTemps- HR Generalist C. Gallow		502-406-60010	44.45
	130659	01/26 MuniTemps- HR Generalist C. Gallow		502-510-60010	111.13
	130659	01/26 MuniTemps- HR Generalist C. Gallow		503-406-60010	33.34
	130659	01/26 MuniTemps- HR Generalist C. Gallow		503-520-60010	66.68
	130659	01/26 MuniTemps- HR Generalist C. Gallow		503-521-60010	33.34
	130659	01/26 MuniTemps- HR Generalist C. Gallow		504-535-60010	22.23
	130659	01/26 MuniTemps- HR Generalist C. Gallow		820-610-60010	22.19
80561	2/5/2026	1445	GRAINGER		487.02
	8768025497	1/26 WWP Fiber Glass Repair Kit		501-503-70140	80.78
	9768892482	1/26 WWP New Solenoid Valves		501-503-84020	406.24
80562	2/5/2026	1446	Granite Construction Company		434.09
	3131308	1/26 PW Water Leak Base Lock		501-508-70140	434.09
80563	2/5/2026	1451	Hach Company		7,541.56
	14824458	1/26 WWP 1/4 LY Maintenance		501-503-84020	7,541.56
80564	2/5/2026	1463	Hill Brothers Chemical Company		5,325.36
	INV13145688	1/26 WWP Chemical Ammonia		501-503-70210	5,325.36

Check Register

Payment Dates: 2/1/2026 - 2/28/2026

Payment Number	Payment Date Payable Number	Vendor # Description	Vendor Name	Account Number	Payment Amount Item Amount
80565	2/5/2026 26-147	02508 1/26 FD H. Crosswy CPR Instructor Course	Howard Main	117-416-70050	525.00 525.00
80566	2/5/2026 TR21222	02748 2/26 PD Meal Advance J. Vega	Jose Angel Vega	101-413-86010	299.00 299.00
80567	2/5/2026 50270432	1553 1/26 PD Vehicle Parts C2	Keller Ford	101-413-84060	226.35 226.35
80568	2/5/2026 CM51327 INV1032297	02626 1/26 FD PPE Boots Credit Memo 1/26 FD PPE Gloves	L.N. Curtis and Sons	101-416-70102 101-416-70102	166.73 -647.86 814.59
80569	2/5/2026 2056221 2059784	1593 1/26 FD Medical Supplies 1/26 FD Medical Supplies	Life Assist, Inc.	117-416-75000 117-416-75000	5,261.34 4,103.94 1,157.40
80570	2/5/2026 54730631	02570 1/26 FD Oxygen	Linde Gas & Equipment Inc.	117-416-75000	935.63 935.63
80571	2/5/2026 8273	02733 12/25 BSCC ORT 6/ Cameras	Low Voltage Service, Inc	106-413-98040	26,392.88 26,392.88
80572	2/5/2026 11343 11345	03043 1/26 PD Diagnostic #C16 1/26 PD Filters/Wipers	LUIS ANGEL GUZMAN	101-413-84060 101-413-84060	235.00 60.00 175.00
80573	2/5/2026 3400175	1647 1/26 WWP Tree Removals	Mid Valley Disposal, Inc.	501-503-84051	405.49 405.49
80574	2/5/2026 CA10-00934876 CA10-00934928	1658 1/26 WWP Gear Oil/ Chain 1/26 WWP Oil for Floc Drive	Motion Industries	501-503-84020 501-503-84020	3,093.65 2,718.40 375.25
80575	2/5/2026 116114 116115	1661 1/26 WWP Pest Control Services 1/26 WWP Pest Control Services	Mountain Valley Pest Control, Inc.	503-520-84030 501-503-84030	75.00 30.00 45.00
80576	2/5/2026 456991955001 456998983001	02615 1/26 PD Office Supplies 1/26 PD USB Drives	ODP Business Solutions, LLC	101-413-70010 101-413-70010	173.66 113.11 60.55
80577	2/5/2026 4316-149058 4316-149087 4316-149688 4316-149846 4316-149850	1692 1/26 PD Motor Oil Battery 1/26 PD Vehicle Maint/Repair 1/26 FD M252 Oil/Filter 1/26 PD Oil/Filter C1 1/26 PD Oil Filter/ Wiper Blades P2	O'Reilly Automotive, Inc.	101-413-84060 101-413-84060 117-416-84060 101-413-84060 101-413-84060	794.51 319.07 37.81 232.16 68.92 136.55
80578	2/5/2026 1911135284 1911135284 1911138350	02554 1/26 PW Sandalwood Lift Station Repair 1/26 PW Sandalwood Lift Station Repair 1/26 PW Sandalwood Lift Station Parts	Pace Supply Corp.	501-508-70140 503-521-70140 503-521-70140	1,174.06 129.66 535.12 509.28
80579	2/5/2026 0014532 0014541	1721 1/26 PW Cambridge/Elm Signal (9389051722-5) 2/26 PD Elm/Coalinga Plaza (2751740765-9)	PG&E	110-424-72021 101-413-72020	131.43 107.98 23.45
80580	2/5/2026 INV0845 INV0859	02664 1/26 WWP Troubleshoot Hypo Motor 1/26 WWP Repair Floc Breaker	PHILLIPS ELECTRIC, LLC	501-503-84020 501-503-84020	1,630.00 550.00 1,080.00
80581	2/5/2026 37609 37609	02726 1/26 FY 24/25 Accounting & Auditing Services 1/26 FY 24/25 Accounting & Auditing Services	Price Paige & Company, Certified Public Accountants, LLP	101-406-88030 107-422-88030	22,016.00 3,742.72 1,100.80

Check Register

Payment Dates: 2/1/2026 - 2/28/2026

Payment Number	Payment Date Payable Number	Vendor # Description	Vendor Name	Account Number	Payment Amount Item Amount
	37609	1/26 FY 24/25 Accounting & Auditing Services		501-406-88030	6,384.64
	37609	1/26 FY 24/25 Accounting & Auditing Services		502-406-88030	5,504.00
	37609	1/26 FY 24/25 Accounting & Auditing Services		503-406-88030	4,183.04
	37609	1/26 FY 24/25 Accounting & Auditing Services		504-406-88030	220.16
	37609	1/26 FY 24/25 Accounting & Auditing Services		820-610-88030	880.64
80582	2/5/2026 2150207	02637 1/26 PD Phone Services 2/1-2/28/26	PTS Communications Inc	101-413-72030	100.00 100.00
80583	2/5/2026 14702 14837	02048 12/25 FY25/26 Continuing Disclosure 12/25 FY25/26 Successor Agency Services	RSG, INC.	820-610-96512 820-610-88100	371.25 135.00 236.25
80584	2/5/2026 SLDMWA-MAR2026 SLDMWA-MAR2026 SLDMWA-MAR2026	1804 January 2026 Estimate March 2026 Estimate January 2026 Adjustment	San Luis & Delta-Mendota	501-503-80010 501-503-80010 501-503-80010	22,990.50 -11,239.80 15,327.00 18,903.30
80585	2/5/2026 COLADMDEC-25	1821 12/25 Dec 25/26 Loan Servicing Fees	Self Help Enterprises	815-609-88100	261.00 261.00
80586	2/5/2026 83830	02368 1/26 PD Training	Southern California Intergovernmental Training And Development Center	101-413-86010	625.00 625.00
80587	2/5/2026 8013274716 8013274716 8013274716 8013274716 8013274716 8013274716 8013274716 8013274716 8013274716 8013274716 8013274716 8013274716 8013274716 8013274716 8013274716 8013274716 8013274716 8013274716 8013274716	02694 Admin Shred-It Services 2/1-2/28/26 FIN Shred-It Services 2/1-2/28/26 HR Shred-It Services 2/1-2/28/26 HR Shred-It Services 2/1-2/28/26 HRShred-It Services 2/1-2/28/26 HR Shred-It Services 2/1-2/28/26 HR Shred-It Services 2/1-2/28/26 HR Shred-It Services 2/1-2/28/26 HR Shred-It Services 2/1-2/28/26 HR Shred-It Services 2/1-2/28/26 HR Shred-It Services 2/1-2/28/26 HR Shred-It Services 2/1-2/28/26 HR Shred-It Services 2/1-2/28/26 HR Shred-It Services 2/1-2/28/26 HR Shred-It Services 2/1-2/28/26 HR Shred-It Services 2/1-2/28/26 HR Shred-It Services 2/1-2/28/26 HR Shred-It Services 2/1-2/28/26 HR Shred-It Services 2/1-2/28/26 HR Shred-It Services 2/1-2/28/26	Stericycle, Inc.	101-405-88100 101-406-82040 101-408-88100 107-422-88100 117-416-88100 501-406-88100 501-503-88100 501-508-88100 502-406-88100 502-510-88100 503-406-88100 503-520-88100 503-521-88100 504-535-88100 820-610-88100	113.14 37.71 37.72 21.49 0.75 4.90 0.75 2.26 1.89 0.75 1.89 0.57 1.13 0.57 0.38 0.38
80588	2/5/2026 HINV025776 HINV025776 HINV025776	1879 1/26 PW Uniforms Safety Equipment 1/26 PW Uniforms Safety Equipment 1/26 PW Uniforms Safety Equipment	Summit Safety, LLC	501-508-70101 502-510-70101 503-521-70101	1,329.92 443.31 443.31 443.30
80589	2/5/2026 853167119	1920 2/26 PD Clears Subscription	Thomson Reuters/Barclays	101-413-86030	757.10 757.10
80590	2/5/2026 0014539 0014539 0014539 0014539 0014539 0014539 0014539 0014539 0014539 0014539 0014539 0014539 0014539 0014539 0014539 0014539 0014539 0014539 0014539	02846 307-0101 MDT 307-0100 MDT 974-4689 Dispatch Back Up 446-5369 Seese 307-0115 MDT 307-0102 MDT 307-0103 MDT 307-0109 MDT 307-0108 MDT 307-0116 MDT 307-0107 MDT 307-0106 MDT	T-MOBILE USA INC	101-413-72030 101-413-72030 101-413-72030 101-413-72030 101-413-72030 101-413-72030 101-413-72030 101-413-72030 101-413-72030 101-413-72030 101-413-72030 101-413-72030 101-413-72030 101-413-72030 101-413-72030 101-413-72030 101-413-72030 101-413-72030 101-413-72030	1,029.69 31.00 31.00 43.91 39.69 31.00 31.00 31.00 31.00 31.00 31.00 31.00 31.00 31.00 31.00 31.00 31.00 31.00 31.00

Check Register

Payment Dates: 2/1/2026 - 2/28/2026

Payment Number	Payment Date Payable Number	Vendor # Description	Vendor Name	Account Number	Payment Amount Item Amount
	0014539	307-0118 MDT		101-413-72030	31.00
	0014539	307-0105 MDT		101-413-72030	31.00
	0014539	307-0119 MDT		101-413-72030	31.00
	0014539	307-0104 MDT		101-413-72030	31.00
	0014539	341-7512 Arroyo		101-413-72030	39.69
	0014539	307-0117 MDT		101-413-72030	31.00
	0014539	307-0099 MDT		101-413-72030	31.00
	0014539	690-4692 Young		101-413-72030	34.89
	0014539	307-0097 MDT		101-413-72030	31.00
	0014539	974-6734 Kaiser		101-413-72030	43.91
	0014539	446-5077 Sparks		101-413-72030	43.91
	0014539	307-0098 MDT		101-413-72030	31.00
	0014539	307-0094 MDT		101-413-72030	31.00
	0014539	307-0095 MDT		101-413-72030	31.00
	0014539	307-0114 MDT		101-413-72030	31.00
	0014539	307-0113 MDT		101-413-72030	31.00
	0014539	307-0096 MDT		101-413-72030	31.00
	0014539	978-7681 Diaz		101-413-72030	39.69
	0014539	307-0112 MDT		101-413-72030	31.00
80593	2/5/2026	02846	T-MOBILE USA INC		189.46
	0013613	383-4514 WP Primary 100%		501-503-72030	39.68
	0013613	341-9613 WP On-Call 100%		501-503-72030	43.89
	0013613	307-0123 Mobile Internet 100%		501-503-72030	31.00
	0013613	362-6567 Field Supervisor 50% - Uribe		501-503-72030	21.95
	0013613	307-0124 Mobile Internet 100%		501-503-72030	31.00
	0013613	362-6567 Field Supervisor 50% - Uribe		503-520-72030	21.94
80594	2/5/2026	03065	TOWNSEND PUBLIC AFFAIRS INC		5,000.00
	24710	02/26 Lobbying & Econ Development Services FY25-		101-401-88100	500.00
	24710	02/26 Lobbying & Econ Development Services FY25-		107-422-88100	750.00
	24710	02/26 Lobbying & Econ Development Services FY25-		501-503-88100	750.00
	24710	02/26 Lobbying & Econ Development Services FY25-		501-508-88100	750.00
	24710	02/26 Lobbying & Econ Development Services FY25-		502-510-88100	750.00
	24710	02/26 Lobbying & Econ Development Services FY25-		503-520-88100	750.00
	24710	02/26 Lobbying & Econ Development Services FY25-		503-521-88100	750.00
80595	2/5/2026	02351	Tractor Supply Company		96.39
	101359	1/26 PW Propane for Patch Truck		107-422-70130	96.39
80596	2/5/2026	02185	Unwired Broadband		901.97
	INV02612601	1/26 WWP WiFi		501-503-72030	901.97
80597	2/5/2026	1944 CC	US Bank Corporate Payment Center		4,564.25
	USB-PD-DEC2025-3	12/25 PD Armor		101-413-70101	219.95
	USB-PD-DEC2025-3	12/25 PD Range		101-413-70101	690.79
	USB-PD-DEC2025-3	12/25 PD Uniform Equipment		101-413-70101	315.76
	USB-PD-DEC2025-3	12/25 PD Training		101-413-86010	375.00
	USB-PD-DEC2025-3	12/25 PD Microsoft		101-413-88040	199.20
	USB-PD-DEC2025-3	12/25 PD K9 Membership		101-413-92211	45.00
	USB-PD-DEC2025-3	12/25 PD Armory		105-413-98041	317.14
	USB-PD-DEC2025-3	12/25 PD Armor		105-413-98041	420.90
	USB-PD-DEC2025-3	12/25 PD Range		105-413-98041	1,980.51
80598	2/5/2026	1964	USABluebook		943.55
	INV00948125	1/26 PW Water Shut Off Tool(2)		501-508-70060	943.55
80599	2/5/2026	02864	VESTIS GROUP INC ARAMARK UNIFORM & APPAREL LLC		541.14
	5031676974	1/26 PD Jail Blankets		101-413-70380	541.14
80600	2/5/2026	1993	West Hills Oil, Inc.		21,021.18
	85227	1/26 FD January 2026 Fuel		101-416-70160	11,389.92

Check Register

Payment Dates: 2/1/2026 - 2/28/2026

Payment Number	Payment Date Payable Number	Vendor # Description	Vendor Name	Account Number	Payment Amount Item Amount
	0014553	1/26 PW Janitorial Services		503-521-84030	141.66
80612	2/12/2026 11117	03031 2/26 Backflow Test Reading & Monitoring	BACKFLOW SOLUTIONS INC	501-508-86030	995.00 995.00
80613	2/12/2026 22193	02698 2/26 PW Help With Water Leak (Welder)	Bear Trap Enterprises Inc.	501-508-88100	3,943.81 3,943.81
80614	2/12/2026 CLG-311030	1112 2/26 FD M253 Oil Filters	BILLINGSLEY TIRE SERVICE	117-416-84060	624.32 624.32
80615	2/12/2026 05G8730097787 05G8730097787 06A8730097787 06A8730097787	03040 2/26 PW Water Delivery Cup Ajustment 2/26 PW Water Delivery Cup Ajustment 2/26 PW Water Delivery 2/26 PW Water Delivery	BLUETRITON BRANDS INC	502-510-70440 503-521-70440 502-510-70440 503-521-70440	84.83 20.02 20.02 22.40 22.39
80616	2/12/2026 26-020201	02504 2/26 WP New Remote Meter	Brian Corley	501-503-84020	808.20 808.20
80617	2/12/2026 AJ02522 AJ02522	02296 2/26 WP Outside Lab Work 2/26 WP Outside Lab Work	BSK Associates	501-503-88081 503-520-88080	3,032.50 2,522.50 510.00
80618	2/12/2026 90353320	1192 2/26 WP Alum Chemical	Chemtrade Chemicals US, LLC	501-503-70240	8,075.97 8,075.97
80619	2/12/2026 4258393734 4258393734 4258393734 4258393734 4258393734 4258393734 4258393734 4258393734 4258393734 4258393734 4258393734 4258393734 4258393734 4258393734	02594 2/26 BLDG Employee Uniforms/Sanitary Supplies/M 2/26 SC Employee Uniforms/Sanitary Supplies/Mats 2/26 ADM Employee Uniforms/Sanitary Supplies/Ma 2/26 MG Employee Uniforms/Sanitary Supplies/Mat 2/26 GT Employee Uniforms/Sanitary Supplies/Mats 2/26 WTP Employee Uniforms/Sanitary Supplies/Ma 2/26 WD Employee Uniforms/Sanitary Supplies/Mat 2/26 MR Employee Uniforms/Sanitary Supplies/Mat 2/26 GE Employee Uniforms/Sanitary Supplies/Mats 2/26 MR Employee Uniforms/Sanitary Supplies/Mat 2/26 WWTP Employee Uniforms/Sanitary Supplies/ 2/26 WWC Employee Uniforms/Sanitary Supplies/M	CINTAS CORPORATION #3	101-404-70100 101-431-70100 101-432-84030 101-440-70100 107-422-70100 501-503-70100 501-508-70100 501-508-70100 502-510-70100 502-510-70100 503-520-70100 503-521-70100	561.07 13.06 45.37 72.71 85.76 52.81 58.89 52.81 23.34 52.81 23.34 27.36 52.81
80620	2/12/2026 839293 839334 839343 839348 839351 839457 839466 839519 839544	1224 2/26 WP Misc Supplies 2/26 PW Fasteners 2/26 FD Building Maint. 2/26 PW PVC Water Parts 2/26 WP Pipe Supplies 2/26 Airport Transfueler 2/26 Transfueler Wiring 2/26 FD Toilet Seat Cover Pans Building 2/26 Transfueler Wiring Repair Circuit Board	COALINGA HARDWARE	503-520-70140 501-508-70140 101-416-84030 501-508-70140 501-503-70140 101-435-84030 101-435-84030 101-435-84030 101-416-84030 101-435-84030	506.94 148.59 27.84 39.92 43.78 24.16 25.42 27.43 164.63 5.17
80621	2/12/2026 998461 998462 998464 998465 999505 999506 999507 999508	02581 2/26 PD Vehicles 2/26 PD Vehicle 2/26 PD Vehicles 2/26 PD Vehicles 2/26 PD Vehicles VIN: TGA28783 2/26 PD Vehicles VIN: TGA21002 2/26 PD Vehicles VIN: TGA28106 2/26 PD Vehicles VIN: TGA19594	Dana Safety Supply	101-413-98040 101-413-98040 101-413-98040 101-413-98040 101-413-98040 101-413-98040 101-413-98040 101-413-98040	107,517.68 26,052.30 26,052.30 26,052.30 26,052.30 827.12 827.12 827.12 827.12

Check Register

Payment Dates: 2/1/2026 - 2/28/2026

Payment Number	Payment Date Payable Number	Vendor # Description	Vendor Name	Account Number	Payment Amount Item Amount
	19758146	2/26 FIN Copier Lease		504-406-84010	3.47
	19758146	2/26 HR Copier Lease		820-610-84010	1.11
80634	2/12/2026	1593	Life Assist, Inc.		3,531.37
	2059740	2/26 FD Medical Supplies		117-416-75000	2,265.57
	2061207	2/26 FD Medical Supplies		117-416-75000	225.00
	2063045	2/26 FD Medical Supplies		117-416-75000	1,040.80
80635	2/12/2026	03069	OPTIMIZED INVESTMENT PARTNERS LLC		2,349.39
	1584	1/26 Investment Advisory Services		101-406-88100	1,033.73
	1584	1/26 Investment Advisory Services		501-406-88100	634.34
	1584	1/26 Investment Advisory Services		502-406-88100	70.48
	1584	1/26 Investment Advisory Services		503-406-88100	610.84
80636	2/12/2026	1692	O'Reilly Automotive, Inc.		1,401.14
	4316-145674	2/26 PD Wipers		101-413-84060	70.83
	4316-150331	2/26 PW Shop Tools		101-431-70060	184.65
	4316-150332	2/26 PD Heater Hose		101-413-84060	159.32
	4316-150368	2/26 PD Filter/Oil C21		101-413-84060	100.43
	4316-150408	2/26 PD Brake Pads C21		101-413-84060	418.29
	4316-150481	2/26 PD Oil/Filter C15		101-413-84060	72.97
	4316-150482	2/26 PD Oil/Filter C2		101-413-84060	72.97
	4316-150483	2/26 PD Torque Mount C15		101-413-84060	53.40
	4316-150492	2/26 PD Filter/Oil #C7		101-413-84060	45.70
	4316-150501	2/26 PW Oil Change #16		107-422-84060	36.36
	4316-151005	2/26 PW Shop Tools		101-431-70060	110.02
	4316-151157	2/26 PD Filter/Oil C10		101-413-84060	76.20
80637	2/12/2026	1744	QTpod		633.69
	8885	2/26 M4000- Circuit Board		101-435-84030	633.69
80638	2/12/2026	02318	Quadient Finance USA, Inc.		1,500.00
	0014547	2/26 FIN Postage Purchased		501-406-70030	600.00
	0014547	2/26 FIN Postage Purchased		502-406-70030	525.00
	0014547	2/26 FIN Postage Purchased		503-406-70030	345.00
	0014547	2/26 FIN Postage Purchased		504-406-70030	30.00
80639	2/12/2026	1763	Resolve Insurance Systems, Inc.		4,523.90
	JANUARY2026	2/26 FD Amb Collections		117-416-75040	4,523.90
80640	2/12/2026	1821	Self Help Enterprises		16,260.83
	COL22H1/20/2026	1/26 SHE DEC 25/26 22CDBG FTHB Grant Fees		303-405-88118	917.01
	COL22RH1/20/2026	1/26 SHE DEC 25/26 22 CDBG Rehab Grant Fees		303-405-88118	15,343.82
80641	2/12/2026	03027	SIG SAUER, INC		1,261.94
	5068216	2/26 PD Armor/Range		101-413-70101	1,261.94
80642	2/12/2026	02249	Stanley Access Technologies		600.00
	90121568	2/26 Annual Maintenance for Lobby Door		101-432-84030	600.00
80643	2/12/2026	03130	Steno Agency, Inc.		3,709.51
	2345067	2/26 Cano Vs COC Terminaton Appeal Hearing Servic		101-401-88100	1,328.36
	2353730	2/26 Cano Vs COC Terminaton Appeal Hearing Servic		101-401-88100	2,381.15
80644	2/12/2026	02567	Stephen Griswold		388.00
	INV1105	2/26 Annual Fire Extinguisher Inspection-City Hall		101-432-84071	128.00
	INV1108	2/26 Airport Annual Fire Extinguisher Inspection		101-435-88100	260.00
80645	2/12/2026	02694	Stericycle, Inc.		203.26
	8013267328	2/26 FD Hazardeous Waste		117-416-75000	203.26
80646	2/12/2026	02523	Taylor Corporation		127.66
	9649559	2/26 Business Cards A. Arroyo		101-401-70010	63.83

Check Register

Payment Dates: 2/1/2026 - 2/28/2026

Payment Number	Payment Date Payable Number	Vendor # Description	Vendor Name	Account Number	Payment Amount Item Amount
	9649559	2/26 Business Cards R. Schindler		101-401-70010	63.83
80647	2/12/2026 130577	1898 2/26 WP Reprogram N.W. Booster STA	Telstar Instruments, Inc.	501-503-84020	1,176.00 1,176.00
80648	2/12/2026	02846	T-MOBILE USA INC		407.39
	0014550	698-4142 SVC Center - Pedro 100%		101-431-72030	43.91
	0014550	381-1988 PW Meter Reader 40%		501-406-72030	17.56
	0014550	341-4461 PW Director 20%		501-503-72030	7.94
	0014550	307-0128 PW UB Tablet 6 34%		501-508-72030	7.26
	0014550	341-4461 PW Director 20%		501-508-72030	7.94
	0014550	974-1257 PW Supervisor Phone 34%		501-508-72030	14.93
	0014550	383-4014 PW Standby 34%		501-508-72030	14.93
	0014550	307-0133 PW UB Tablet 8 34%		501-508-72030	7.26
	0014550	307-0126 GIS Tablet 34%		501-508-72030	7.26
	0014550	307-0127 PW UB Tablet 1 34%		501-508-72030	7.26
	0014550	307-0129 PW UB Tablet 2 34%		501-508-72030	7.26
	0014550	307-0130 PW UB Tablet 3 34%		501-508-72030	7.26
	0014550	307-0131 PW UB Tablet 4 34%		501-508-72030	7.26
	0014550	690-5459 PW Tablets		501-508-72030	7.26
	0014550	307-0132 PW UB Tablet 5 34%		501-508-72030	7.26
	0014550	381-1988 PW Meter Reader 35%		502-406-72030	15.37
	0014550	307-0127 PW UB Tablet 1 33%		502-510-72030	7.04
	0014550	307-0126 GIS Tablet 33%		502-510-72030	7.04
	0014550	341-4461 PW Director 20%		502-510-72030	7.93
	0014550	974-1257 PW Supervisor Phone 33%		502-510-72030	14.49
	0014550	383-4014 PW Standby 33%		502-510-72030	14.49
	0014550	307-0128 PW UB Tablet 6 33%		502-510-72030	7.04
	0014550	307-0132 PW UB Tablet 5 33%		502-510-72030	7.04
	0014550	307-0133 PW UB Tablet 8 33%		502-510-72030	7.04
	0014550	690-5459 PW Tablets 33%		502-510-72030	7.04
	0014550	307-0129 PW UB Tablet 2 33%		502-510-72030	7.04
	0014550	307-0131 PW UB Tablet 4 33%		502-510-72030	7.04
	0014550	307-0130 PW UB Tablet 3 33%		502-510-72030	7.04
	0014550	381-1988 PW Meter Reader 23%		503-406-72030	10.09
	0014550	341-4461 PW Director 20%		503-520-72030	7.94
	0014550	307-0133 PW UB Tablet 8 33%		503-521-72030	7.04
	0014550	307-0128 PW UB Tablet 6 33%		503-521-72030	7.04
	0014550	307-0132 PW UB Tablet 5 33%		503-521-72030	7.04
	0014550	307-0131 PW UB Tablet 4 33%		503-521-72030	7.04
	0014550	307-0130 PW UB Tablet 3 33%		503-521-72030	7.04
	0014550	307-0129 PW UB Tablet 2 33%		503-521-72030	7.04
	0014550	307-0126 GIS Tablet 33%		503-521-72030	7.04
	0014550	341-4461 PW Director 20%		503-521-72030	7.94
	0014550	307-0127 PW UB Tablet 1 33%		503-521-72030	7.04
	0014550	974-1257 PW Supervisor Phone 33%		503-521-72030	14.49
	0014550	383-4014 PW Standby 33%		503-521-72030	14.49
	0014550	690-5459 PW Tablets 33%		503-521-72030	7.04
	0014550	381-1988 PW Meter Reader 2%		504-406-72030	0.89
80651	2/12/2026	02846	T-MOBILE USA INC		320.97
	0014548	559-307-0084 100% Council Member		101-401-72030	31.00
	0014548	559-307-0083 100% Council Member		101-401-72030	31.00
	0014548	559-307-0082 100% Council Member		101-401-72030	31.00
	0014548	559-307-0081 100% Council Member		101-401-72030	31.00
	0014548	559-307-0080 100% Council Member		101-401-72030	31.00
	0014548	559-942-1649 100% BLDG Inspector IPad		101-404-72030	21.34
	0014548	559-630-2536 100% R. Smith		101-404-72030	43.97
	0014548	559-885-2481 100% Code Enforcer IPad		101-405-72030	21.34
	0014548	559-246-6243 50% M. Garcia		101-405-72030	19.84

Check Register

Payment Dates: 2/1/2026 - 2/28/2026

Payment Number	Payment Date Payable Number	Vendor # Description	Vendor Name	Account Number	Payment Amount Item Amount
	0014548	559-401-9377	15% Financial Svcs Director	101-406-72030	5.95
	0014548	559-246-6243	50% M. Garcia	101-435-72030	19.84
	0014548	559-401-9377	5% Financial Svcs Director	107-422-72030	1.99
	0014548	559-401-9377	30% Financial Svcs Director	501-406-72030	11.91
	0014548	559-401-9377	25% Financial Svcs Director	502-406-72030	9.92
	0014548	559-401-9377	19% Financial Svcs Director	503-406-72030	7.54
	0014548	559-401-9377	1% Financial Svcs Director	504-406-72030	0.34
	0014548	559-401-9377	5% Financial Svcs Director	820-610-72030	1.99
80653	2/12/2026	02351	Tractor Supply Company		41.46
	103410	2/26 PW Hand Cleanser		501-508-84030	41.46
80654	2/12/2026	1944 CC	US Bank Corporate Payment Center		2,924.72
	USB-WP-JAN2026	1/26 CallCentric SCADA		501-503-84020	29.95
	USB-WP-JAN2026	1/26 Office Depot - New Monitors		501-503-98030	261.52
	USB-WP-JAN2026	1/26 Office Depot-New Monitors		501-503-98030	239.72
	USB-WP-JAN2026	1/26 Mcdonald's Food for Water Leak		501-508-86010	80.92
	USB-WP-JAN2026	1/26 McDonalds's- Food for Water Leak		501-508-86010	73.63
	USB-WP-JAN2026	1/26 Office Depot- Office Supplies		503-520-70010	206.15
	USB-WP-JAN2026	1/26 Office Depot- Binders		503-520-70140	107.44
	USB-WP-JAN2026	1/26 Amazon-Disposable Gloves		503-520-70140	595.21
	USB-WP-JAN2026	1/26 Old Gen Johanson Thomas- Sewer Parts		503-520-84020	1,330.18
80655	2/12/2026	1964	USABluebook		4,625.57
	INV00948208	2/26 WP Mono ChemKey		501-503-70202	668.59
	INV00948292	2/26 WP Chemical Reagents/Chemkey		501-503-70202	3,453.76
	INV00950740	2/26 WP Wide Mouth Bottles		501-503-70202	503.22
80656	2/12/2026	02864	VESTIS GROUP INC ARAMARK UNIFORM & APPAREL LLC		541.14
	5031682614	2/26 PD Jail Blankets		101-413-70380	541.14
80657	2/12/2026	1983	WageWorks		79.20
	INV8649326	2/26 FSA Monthly Charges S. Brewer		101-404-88101	0.46
	INV8649326	2/26 FSA Monthly Charges M. Garcia		101-405-88101	2.64
	INV8649326	2/26 FSA Monthly Charges Y. Ibarra		101-405-88101	4.95
	INV8649326	2/26 FSA Monthly Charges S. Brewer		101-405-88101	0.46
	INV8649326	2/26 FSA Monthly Charges M. Trejo		101-405-88101	1.12
	INV8649326	2/26 FSA Monthly Charges S. Jensen		101-405-88101	3.70
	INV8649326	2/26 FSA Monthly Charges C. Aguilar		101-405-88101	1.12
	INV8649326	2/26 FSA Monthly Charges S. Redding		101-408-88101	3.76
	INV8649326	2/26 FSA Monthly Charges S. Anderson		101-413-88101	6.60
	INV8649326	2/26 FSA Monthly Charges V. Sparks		101-413-88101	6.60
	INV8649326	2/26 FSA Monthly Charges C. Seese		101-413-88101	6.60
	INV8649326	2/26 FSA Monthly Charges M. Garcia		101-435-88101	1.98
	INV8649326	2/26 FSA Monthly Charges S. Redding		107-422-88101	0.13
	INV8649326	2/26 FSA Monthly Charges C. Aguilar		107-422-88101	0.40
	INV8649326	2/26 FSA Monthly Charges M. Trejo		107-422-88101	0.40
	INV8649326	2/26 FSA Monthly Charges S. Brewer		107-422-88101	1.32
	INV8649326	2/26 FSA Monthly Charges S. Jensen		107-422-88101	0.46
	INV8649326	2/26 FSA Monthly Charges S. Jensen		117-416-88101	0.07
	INV8649326	2/26 FSA Monthly Charges S. Redding		117-416-88101	0.86
	INV8649326	2/26 FSA Monthly Charges S. Redding		501-406-88101	0.13
	INV8649326	2/26 FSA Monthly Charges C. Aguilar		501-406-88101	0.08
	INV8649326	2/26 FSA Monthly Charges M. Trejo		501-406-88101	0.08
	INV8649326	2/26 FSA Monthly Charges J. Salona		501-503-88101	6.60
	INV8649326	2/26 FSA Monthly Charges A. Uribe		501-503-88101	4.62
	INV8649326	2/26 FSA Monthly Charges S. Brewer		501-503-88101	0.66
	INV8649326	2/26 FSA Monthly Charges Y. Ibarra		501-503-88101	1.65
	INV8649326	2/26 FSA Monthly Charges S. Redding		501-503-88101	0.40
	INV8649326	2/26 FSA Monthly Charges S. Jensen		501-503-88101	0.26
	INV8649326	2/26 FSA Monthly Charges M. Trejo		501-503-88101	0.89

Check Register

Payment Dates: 2/1/2026 - 2/28/2026

Payment Number	Payment Date Payable Number	Vendor # Description	Vendor Name	Account Number	Payment Amount Item Amount
	INV8649326	2/26 FSA Monthly Charges C. Aguilar		501-503-88101	0.89
	INV8649326	2/26 FSA Monthly Charges M. Trejo		501-508-88101	0.92
	INV8649326	2/26 FSA Monthly Charges S. Brewer		501-508-88101	0.33
	INV8649326	2/26 FSA Monthly Charges S. Redding		501-508-88101	0.33
	INV8649326	2/26 FSA Monthly Charges S. Jensen		501-508-88101	0.43
	INV8649326	2/26 FSA Monthly Charges C. Aguilar		501-508-88101	0.92
	INV8649326	2/26 FSA Monthly Charges M. Trejo		502-406-88101	0.06
	INV8649326	2/26 FSA Monthly Charges C. Aguilar		502-406-88101	0.06
	INV8649326	2/26 FSA Monthly Charges S. Redding		502-406-88101	0.13
	INV8649326	2/26 FSA Monthly Charges S. Brewer		502-510-88101	0.99
	INV8649326	2/26 FSA Monthly Charges S. Jensen		502-510-88101	0.13
	INV8649326	2/26 FSA Monthly Charges S. Redding		502-510-88101	0.33
	INV8649326	2/26 FSA Monthly Charges M. Trejo		502-510-88101	0.89
	INV8649326	2/26 FSA Monthly Charges C. Aguilar		502-510-88101	0.89
	INV8649326	2/26 FSA Monthly Charges M. Garcia		502-510-88101	1.98
	INV8649326	2/26 FSA Monthly Charges M. Trejo		503-406-88101	0.04
	INV8649326	2/26 FSA Monthly Charges C. Aguilar		503-406-88101	0.04
	INV8649326	2/26 FSA Monthly Charges S. Redding		503-406-88101	0.10
	INV8649326	2/26 FSA Monthly Charges S. Brewer		503-520-88101	0.99
	INV8649326	2/26 FSA Monthly Charges S. Redding		503-520-88101	0.20
	INV8649326	2/26 FSA Monthly Charges S. Jensen		503-520-88101	0.13
	INV8649326	2/26 FSA Monthly Charges C. Aguilar		503-520-88101	0.89
	INV8649326	2/26 FSA Monthly Charges M. Trejo		503-520-88101	0.89
	INV8649326	2/26 FSA Monthly Charges A. Uribe		503-520-88101	1.98
	INV8649326	2/26 FSA Monthly Charges S. Brewer		503-521-88101	0.99
	INV8649326	2/26 FSA Monthly Charges M. Trejo		503-521-88101	0.89
	INV8649326	2/26 FSA Monthly Charges C. Aguilar		503-521-88101	0.89
	INV8649326	2/26 FSA Monthly Charges S. Redding		503-521-88101	0.10
	INV8649326	2/26 FSA Monthly Charges S. Jensen		503-521-88101	0.03
	INV8649326	2/26 FSA Monthly Charges C. Aguilar		504-406-88101	0.02
	INV8649326	2/26 FSA Monthly Charges M. Trejo		504-406-88101	0.02
	INV8649326	2/26 FSA Monthly Charges S. Redding		504-535-88101	0.07
	INV8649326	2/26 FSA Monthly Charges S. Jensen		504-535-88101	0.07
	INV8649326	2/26 FSA Monthly Charges S. Redding		820-610-88101	0.07
	INV8649326	2/26 FSA Monthly Charges S. Brewer		820-610-88101	0.40
	INV8649326	2/26 FSA Monthly Charges C. Aguilar		820-610-88101	0.39
	INV8649326	2/26 FSA Monthly Charges M. Trejo		820-610-88101	0.40
	INV8649326	2/26 FSA Monthly Charges S. Jensen		820-610-88101	1.32
80662	2/12/2026	1991	West Hills Machine Shop, Inc.		1,148.11
	052229	2/26 PW Water Leak Materials		501-508-70140	793.40
	052244	2/269 FD M255 Repairs		117-416-84060	354.71
80663	2/12/2026	1993	West Hills Oil, Inc.		11,083.22
	85010	12/25 PW Fuel for Dec 2025		101-404-70160	59.48
	85010	12/25 PW Fuel for Dec 2025		101-440-70160	640.66
	85010	12/25 PW Fuel for Dec 2025		107-422-70160	303.69
	85010	12/25 PW Fuel for Dec 2025		501-508-70160	815.47
	85010	12/25 PW Fuel for Dec 2025		502-510-70160	815.45
	85010	12/25 PW Fuel for Dec 2025		503-521-70160	549.43
	85013	12/25 PW Fuel for Dec 2025		101-440-70160	192.39
	85013	12/25 PW Fuel for Dec 2025		501-508-70160	644.72
	85013	12/25 PW Fuel for Dec 2025		502-510-70160	644.72
	85013	12/25 PW Fuel for Dec 2025		503-521-70160	644.72
	85229	1/26 PW Fuel for Jan 2026		101-404-70160	31.61
	85229	1/26 PW Fuel for Jan 2026		101-440-70160	343.59
	85229	1/26 PW Fuel for Jan 2026		501-508-70160	748.13
	85229	1/26 PW Fuel for Jan 2026		502-510-70160	748.13
	85229	1/26 PW Fuel for Jan 2026		503-521-70160	620.89
	85231	1/26 PW Fuel for Jan 2026		501-406-70160	62.69

Check Register

Payment Dates: 2/1/2026 - 2/28/2026

Payment Number	Payment Date Payable Number	Vendor # Description	Vendor Name	Account Number	Payment Amount Item Amount
	85231	1/26 PW Fuel for Jan 2026		502-406-70160	54.86
	85231	1/26 PW Fuel for Jan 2026		503-406-70160	36.05
	85231	1/26 PW Fuel for Jan 2026		504-406-70160	3.13
	85232	1/26 PW Fuel for Jan 2026		101-440-70160	333.53
	85232	1/26 PW Fuel for Jan 2026		501-508-70160	622.10
	85232	1/26 PW Fuel for Jan 2026		502-510-70160	622.10
	85232	1/26 PW Fuel for Jan 2026		503-521-70160	622.10
	85232	1/26 PW Fuel for Jan 2026		504-535-70160	856.00
	85233	1/26 PW Fuel for Jan2026		101-431-70160	67.58
80665	2/12/2026	1997	Westside Supply		937.92
	19114	1/26 PW Water Leak Part Supplies		501-508-70140	295.72
	19173	1/26 PW Water Leak Supplies		501-508-70140	373.70
	19185	1/26 PW Lift Station Supplies		503-521-70140	128.50
	P260131	1/26 PW Cylinder Rentals		501-508-70140	50.00
	S260131	1/26 PW Cylinder Rental		101-431-70150	30.00
	W260131	1/26 Equipment/ Cylinder Rental		501-503-82030	40.00
	WW260131	1/26 Equipment/ Cylinder Rental		503-520-82030	20.00
80666	2/23/2026	03132	ADVENTIST HEALTH TULARE		165.00
	2742	2/26 PD BAC		101-413-88080	165.00
80667	2/23/2026	03060	ALEXANDER MALKIEWICZ		88.08
	0014663	2/26 FD A. Malkiewicz Meal Reimbursement		117-416-75010	88.08
80668	2/23/2026	02388	AMAZON CAPITAL SERVICES., INC		682.07
	IXG4-DIFK-CRTN	1/26 Dry Erase Markers		101-416-70010	7.89
	IXG4-DIFK-CRTN	1/26 Printer Paper		101-416-70040	91.95
	IXG4-DIFK-CRTN	1/26 Packaging Tape		101-416-70040	13.88
	IXG4-DIFK-CRTN	1/26 Aquasana Filter Replacement		101-416-70450	95.44
	IXG4-DIFK-CRTN	1/26 Clorox Disinfecting Wet Mop (Credit)		101-416-70450	-38.75
	IXG4-DIFK-CRTN	1/26 Garlic Press for Kitchen		101-416-70450	10.91
	IXG4-DIFK-CRTN	1/26 Can Opener		101-416-70450	12.78
	IXG4-DIFK-CRTN	1/26 Shower Head		101-416-84030	47.82
	IXG4-DIFK-CRTN	1/26 Refrigerator Door Light Switch		101-416-84030	8.61
	IXG4-DIFK-CRTN	1/26 DJI Battery Replacement		101-416-84070	431.54
80669	2/23/2026	02386	American Office Solutions, LLC		141.04
	26026	2/26 PW CAT 6-25-Black- QR		501-508-84010	7.02
	26026	2/26 PW CAT 6-25-Black- QR		502-510-84010	7.01
	26026	2/26 PW CAT 6-25-Black- QR		503-521-84010	7.01
	26394	2/26 FD KISI System		101-416-88040	120.00
80670	2/23/2026	1112	BILLINGSLEY TIRE SERVICE		714.74
	CLG-3111199	2/26 PD Wheel Replacement		101-413-84060	516.48
	CLG-311329	2/26 PD Wheel Replacement		101-413-84060	198.26
80671	2/23/2026	1189	Central Valley Toxicology, Inc.		221.00
	344885	1/26 PD Abuse Screen		101-413-88080	38.00
	344886	1/26 PD Drug Screen		101-413-88080	139.00
	344993	2/26 PD BAC		101-413-88080	44.00
80672	2/23/2026	1207	City of Coalinga		1,429.67
	02-00347-031	2/26 Joseph Ray Guerrero Natural Gas Assistance		502-510-80100	123.23
	02-00437-011	2/26 Rosa Torres Natural Gas Assistance		502-510-80100	104.18
	22-084135-005	2/26 Juan Solorio Mora- Natural Gas Assistance		502-510-80100	74.89
	22-08430-001-2	2/26 Carlos Loreda Natural Gas Assistance		502-510-80100	45.99
	33-01740-008	2/26 Francisco C. Espara Natural Gas Assistance		502-510-80100	50.92
	41-02857-021-2	2/26 Nancy Rodriguez Natural Gas Assistance		502-510-80100	178.89
	43-04010-006	2/26 Michael Wilson- Natural Gas Assistance		502-510-80100	192.06
	52-05776-020	2/26 Martha P Torres Cuevas Natural Gas Assistance		502-510-80100	76.34
	52-05776-020-2	2/26 Martha P Torres Cuevas-Natural Gas Assistance		502-510-80100	28.23

Check Register

Payment Dates: 2/1/2026 - 2/28/2026

Payment Number	Payment Date Payable Number	Vendor # Description	Vendor Name	Account Number	Payment Amount Item Amount
	71-11555-010-2	2/26 Longines Trejo Natural Gas Assistance		502-510-80100	183.28
	71-11568-001-2	2/26 Heidi C. Bowerman Natural Gas Assistance		502-510-80100	145.19
	72-09053-015-2	2/26 Magdalen Vargas Natural Gas Assistance		502-510-80100	48.95
	81-09432-008	2/26 Juan Gonzalez- Natural Gas Assistance		502-510-80100	46.97
	81-09773-002	2/26 Maria Toledo Natural Gas Assistance		502-510-80100	130.55
80673	2/23/2026	1207	City of Coalinga		16,434.98
	0014673	90-11379-001 Animal House Fresno/Clga Rd		101-413-72010	62.30
	0014673	01-11035-004 270 S 6th St		101-415-72010	112.09
	0014673	70-08484-001 302 W Elm Firehouse		101-416-72010	2,024.92
	0014673	70-08558-001 160 W Elm - Old City Hall		101-432-72010	19.41
	0014673	70-08559-001 160 W Elm Annex		101-432-72010	63.12
	0014673	70-08563-002 155 W Durian FIN/PD Bldg		101-432-72010	2,469.73
	0014673	70-08562-001 155 W Durian Landscape		101-432-72010	509.17
	0014673	90-10892-002 Coalinga Airport Res		101-435-72010	163.64
	0014673	90-11991-001 Airport Median 1		101-435-72010	48.87
	0014673	90-11992-001 Airport Median 2		101-435-72010	48.87
	0014673	90-11993-001 Airport Median 3		101-435-72010	106.68
	0014673	90-10891-001 27500 W Phelps AP Spencer House		101-435-72010	97.74
	0014673	90-10883-001 27500 W Phelps Airport Acces Road		101-435-72010	57.13
	0014673	90-11994-001 Airport Median 4		101-435-72010	90.16
	0014673	44-11848-002 1 El Rancho Median		101-440-72011	517.35
	0014673	71-11970-001 Forest/Pacific St		101-440-72011	53.17
	0014673	01-11879-001 Plaza Park		101-440-72011	40.52
	0014673	84-12000-001 Sandalwood Park 3		101-440-72011	1,161.64
	0014673	71-08739-001 200 E Pacific		101-440-72011	1,127.00
	0014673	88-11696-003 & Lucille Bourdeaux		101-440-72011	104.89
	0014673	70-08545-001 6th/Elm Parking		101-440-72011	72.89
	0014673	88-11698-003 & Merced Chardonay		101-440-72011	136.64
	0014673	44-11849-002 3 El Rancho Median		101-440-72011	517.35
	0014673	44-11805-002 2 El Rancho Median		101-440-72011	517.35
	0014673	45-11979-001 Centennial Park Lndscpg		101-440-72011	669.76
	0014673	44-11880-001 Centennial Park		101-440-72011	743.85
	0014673	82-10406-001 E Polk/ Warthan Crk Lot		101-440-72011	34.19
	0014673	70-08679-001 Sunset/6th St Vetera		101-440-72011	34.19
	0014673	51-04491-001 E Elm Trees		101-440-72011	34.19
	0014673	51-04490-001 E Aport/Elm Lots		101-440-72011	34.19
	0014673	42-11981-001 W Gale & Hwy 198		101-440-72011	34.19
	0014673	84-11980-001 Jayne Ave- Landscaping		101-440-72011	34.19
	0014673	52-11631-001 Cherry Ln- Median		107-422-72011	36.30
	0014673	84-10693-001 Juniper Ridge/Jayne		107-422-72011	141.15
	0014673	84-10691-003 Juniper/Jayne		107-422-72011	141.15
	0014673	52-11632-001 Cherry Ln- Median2		107-422-72011	34.19
	0014673	82-10397-001 1075 W Elm/Pacific/Lucille		107-422-72011	136.64
	0014673	45-04295-002 Phelps Ave/ La Cuesta		107-422-72011	136.64
	0014673	52-06069-001 Van Ness/Second St lot		107-422-72011	34.19
	0014673	52-11364-001 Cherry Ln- Median 4		107-422-72011	34.19
	0014673	70-12025-000 7th St Irrigation		107-422-72011	34.19
	0014673	62-08395-001 Forest/Second St		107-422-72011	34.19
	0014673	70-11963-001 Cedar/Fifth Clock		107-422-72011	34.19
	0014673	22-08117-001 Hayes Lot		107-422-72011	110.13
	0014673	52-11633-001 Cherry Ln - Median 3		107-422-72011	36.30
	0014673	51-12029-000 Acebedo Ln		107-422-72011	36.31
	0014673	42-03438-001 Van Ness/ Ash St Lot		107-422-72011	38.41
	0014673	82-11910-001 Hwy198/Lucille Landscaping		107-422-72011	34.19
	0014673	61-06870-001 Lynch Park Triangle		107-422-72011	38.41
	0014673	84-10692-001 Juniper Ridge/Jayne		107-422-72011	38.70
	0014673	70-11990-001 Elm/Landscaping 2		107-422-72011	34.19
	0014673	84-11908-001 Copper/Canyon Landscape		107-422-72011	108.02
	0014673	51-12025-001 E. Elm/ Van Ness Trees		107-422-72011	34.19

Check Register

Payment Dates: 2/1/2026 - 2/28/2026

Payment Number	Payment Date Payable Number	Vendor # Description	Vendor Name	Account Number	Payment Amount Item Amount
	0014673	44-04178-001	San Simeon/Posa Chanet	107-422-72011	136.64
	0014673	70-08463-001	290 W Elm Museum	107-422-72011	487.66
	0014673	42-03294-001	Sunset/Fifth Lot	107-422-72011	61.61
	0014673	41-03184-001	W Joaquin/Wash Lot	107-422-72011	633.78
	0014673	01-11987-001	Elm/4th Landscaping 2	107-422-72011	34.19
	0014673	22-08436-001	Forest/First St Lot	107-422-72011	34.19
	0014673	01-11986-001	Elm/4th Landscaping	107-422-72011	34.19
	0014673	41-03130-001	Monterey/Monroe	107-422-72011	544.87
	0014673	84-10736-001	Sandalwood/Longhallow	107-422-72011	49.25
	0014673	70-11988-001	Elm/6th Landscaping	107-422-72011	48.96
	0014673	41-03193-001	Princeton/Wash Lot	107-422-72011	42.63
	0014673	52-12160-000	Cherry Ln -Trail Landscaping	107-422-72011	67.74
	0014673	22-11239-001	Creek Side Lot	107-422-72011	34.19
	0014673	32-01424-001	Hillview/ Monterey	107-422-72011	34.19
	0014673	45-04297-002	Posa Chanet Blvd	107-422-72011	34.19
	0014673	51-04426-001	Baker Rotary Lot	107-422-72011	34.19
	0014673	01-00006-001	200 E Elm- Trees Across Kmart	107-422-72011	34.19
	0014673	82-11346-001	Waste Water Plant	503-520-72010	930.04
	0014673	82-10306-001	Meter Shop	503-521-72010	40.52
	0014673	82-10304-001	Service Yard	503-521-72010	70.51
80678	2/23/2026	1224	COALINGA HARDWARE		230.62
	839582	2/26	FD Sink Repairs	101-416-84030	33.92
	839595	2/26	PD Animal Shelter Concrete	101-416-70440	47.14
	839690	2/26	FD Building Maint./Repairs	101-416-84030	149.56
80679	2/23/2026	02204	CUMULUS Media New Holdings, Inc.		2,500.00
	0014670	2/26	Beverage Container Program	306-426-98580	2,500.00
80680	2/23/2026	1349	Emergency Vehicle Group, Inc.		474.06
	45799	2/26	FD Airbag for M256	117-416-84060	474.06
80681	2/23/2026	1404	Fresno County Fire Protection District		63,382.63
	3246	2/26	FD Huron Station Lease	117-416-75060	7,114.80
	3251	2/26	FD FY25/26 Dispatch & Tablet Command	101-416-75060	56,267.83
80682	2/23/2026	03131	GREGORY HERNANDEZ		14,000.00
	0014666	2/26	City Hall Paint Project Down Payment	101-432-84030	14,000.00
80683	2/23/2026	1450	Griswold, LaSalle, Cobb, Dowd, and Gin, LLP		16,087.26
	20902	12/25	725 S Monterey Ave (General Abatement) Fee	101-401-88010	1,325.55
	20904	12/25	City Council Attorney Fees Dec 2025	101-401-88010	180.00
	20905	12/25	City Clerk Attorney Fees Dec 2025	101-401-88010	1,510.65
	20905	12/25	City Clerk Attorney Fees Dec 2025GasIncrease	502-510-88010	80.67
	20906	12/25	City Manager Attorney Fees Airport Lease	101-401-88010	1,096.66
	20906	12/25	City Manager Attorney Fees	101-401-88010	1,274.92
	20906	12/25	City Manager Attorney Fees Housing Successo	815-609-88100	70.00
	20907	12/25	City Services City Attorney Fees	503-521-88010	949.67
	20908	12/25	Employment Matter (Cano) City Attorney Fee	101-401-88010	6,837.58
	20909	12/25	Finance Dept City Attorney Fees	101-406-88010	1,090.31
	20910	12/25	HR City Attorney Fees	101-401-88010	571.67
	20911	12/25	Labor Relations City Attorney Fees	101-401-88010	714.58
	20912	12/25	Police Dept City Attorney Fees	101-401-88010	385.00
80684	2/23/2026	1494	Interstate Gas Services, Inc.		6,143.00
	7021913	1/26	Utility Consulting for Jan. 2026	501-503-88100	4,983.94
	7021913	1/26	Utility Consulting for Jan. 2026	502-510-88100	1,159.06
80685	2/23/2026	1503	J.P. Cooke Co.		93.95
	918900	2/26	PD Dog Tags	101-415-70440	93.95

Check Register

Payment Dates: 2/1/2026 - 2/28/2026

Payment Number	Payment Date Payable Number	Vendor # Description	Vendor Name	Account Number	Payment Amount Item Amount
80686	2/23/2026	03133	JACQULIN ECHEAGARAY		225.00
	TR-00002	2/26 CSMFO 2026 Conference Meal Advance		101-416-86010	45.00
	TR-00002	2/26 CSMFO 2026 Conference Meal Advance		501-406-86010	67.50
	TR-00002	2/26 CSMFO 2026 Conference Meal Advance		502-406-86010	56.25
	TR-00002	2/26 CSMFO 2026 Conference Meal Advance		503-406-86010	42.75
	TR-00002	2/26 CSMFO 2026 Conference Meal Advance		504-406-86010	2.25
	TR-00002	2/26 CSMFO 2026 Conference Meal Advance		820-610-86010	11.25
80687	2/23/2026	03054	JUAREZ BROTHERS GENERAL ENGINEERING INC		31,485.51
	6	2/26 ATP4 Perimeter Trail 3,4,9 Ret #6		305-000-10003	31,485.51
80688	2/23/2026	1584	League of California Cities		8,442.93
	8242	2/26 South San Joaquin Valley Division Membership		101-405-86030	205.93
	INV-45335-L6P2Y7	2/26 League of California Cities Membership Dues		101-404-86030	8,237.00
80689	2/23/2026	1593	Life Assist, Inc.		2,230.27
	2061086	2/26 FD Medical Supplies		117-416-75000	430.64
	2067695	2/26 FD Medical Supplies		117-416-75000	1,799.63
80690	2/23/2026	03043	LUIS ANGEL GUZMAN		4,555.00
	11343-2	2/26 Vehicle Repair #C-16		101-413-84060	4,555.00
80691	2/23/2026	1621	Mariano Castillo		115.73
	0014669	2/26 Mariano Castillo Natural Gas Assistance		502-510-80100	115.73
80692	2/23/2026	02114	Michee Baggett		212.06
	0014664	11/25 M. Baggett Mileage Reimbursement 11/11-11		101-416-86010	212.06
80693	2/23/2026	1661	Mountain Valley Pest Control, Inc.		84.00
	116224	2/26 PD Pest Control Services		101-413-88100	56.00
	116225	2/26 City Hall Pest Control Services		101-432-84030	28.00
80694	2/23/2026	02625	NDN International LLC		780.03
	JJ2W2710	2/26 PD Uniform Equipment		101-413-70101	780.03
80695	2/23/2026	1686	Northern Safety Co., Inc.		13,663.74
	907395317	1/26 PW PPE Supplies		501-508-70101	4,554.58
	907395317	1/26 PW PPE Supplies		502-510-70101	4,554.58
	907395317	1/26 PW PPE Supplies		503-521-70101	4,554.58
80696	2/23/2026	02615	ODP Business Solutions, LLC		147.84
	456437169001	2/26 PD Staples		101-413-70010	55.78
	456441094001	2/26 PD Office Supplies		101-413-70010	23.42
	458583379001	2/26 PD Key Board		101-413-70010	68.64
80697	2/23/2026	03105	Oososharp, LLC		5,605.49
	53718	2/26 FD Jan Ambulance Billing		117-416-75040	5,605.49
80698	2/23/2026	1692	O'Reilly Automotive, Inc.		285.92
	4316-150893	2/26 FD B171 Battery		101-416-84060	241.73
	4316-151006	2/26 PW Seal Lock for Vac Con		501-508-84060	5.72
	4316-151006	2/26 PW Seal Lock for Vac Con		503-521-84060	5.71
	4316-152421	2/26 FD Amb. Repairs		117-416-84060	32.76
80699	2/23/2026	1721	PG&E		129,917.03
	0014667	2/26 Frame Park (5120357172-7) 12/28/25-1/28/26		101-440-72011	804.35
	90624-013126	2/26 Gas Delivery SE 31 20 15 HWY 12/31-1/31/26		502-510-80020	129,112.68
80700	2/23/2026	1817	Sean Brewer		4.72
	0014671	2/26 Test Payment for Square Inc.		101-435-48163	4.72
80701	2/23/2026	1821	Self Help Enterprises		187.18
	COL20PLHA 1/20/20	12/25 PLHA Grant Admin Costs Dec 2025		306-422-88106	187.18

Check Register

Payment Dates: 2/1/2026 - 2/28/2026

Payment Number	Payment Date Payable Number	Vendor # Description	Vendor Name	Account Number	Payment Amount Item Amount
	USB-FD-JAN2026-5	1/26 Beach Hut Training Meal		101-416-86010	22.55
	USB-FD-JAN2026-5	1/26 California Burrito Training Meal		101-416-86010	18.58
	USB-FD-JAN2026-5	1/26 Drewsks Pit Stop Training Meal		101-416-86010	18.96
	USB-FD-JAN2026-5	1/26 Drewsks Pit Stop Training Meal		101-416-86010	16.66
	USB-FD-JAN2026-6	1/26 ESO Wave H. Crosswy		101-416-70050	1,099.00
	USB-FD-JAN2026-6	1/26 ESO Wave C. Sanchez		101-416-70050	1,099.00
	USB-FD-JAN2026-6	1/26 FSO Wave M. Soto		101-416-70050	1,099.00
	USB-FD-JAN2026-6	1/26 JH Tackett Firefighter Of the Year		101-416-70440	51.81
	USB-FD-JAN2026-6	1/26 Cafe 101 Chiefs Breakfast		101-416-86010	17.10
	USB-FD-JAN2026-6	1/26 Southwest ESO Wave Flights		101-416-86010	1,033.20
	USB-FD-JAN2026-6	1/26 AFSS M. Soto Conference		101-416-86010	525.00
	USB-FD-JAN2026-6	1/26 Cafe 101 Chiefs Breakfast		101-416-86010	21.04
	USB-PD-JAN2026	1/26 PD GoTo City Wide Phone Charges		101-401-72030	114.51
	USB-PD-JAN2026	1/26 PD GoTo City Wide Phone Charges		101-404-72030	45.81
	USB-PD-JAN2026	1/26 PD GoTo City Wide Phone Charges		101-405-72030	114.52
	USB-PD-JAN2026	1/26 PD GoTo City Wide Phone Charges		101-406-72030	6.14
	USB-PD-JAN2026	1/26 PD GoTo City Wide Phone Charges		101-408-72030	23.36
	USB-PD-JAN2026	1/26 PD GoTo City Wide Phone Charges		101-413-72030	526.77
	USB-PD-JAN2026	1/26 Cafe 101		101-413-86010	12.77
	USB-PD-JAN2026	1/26 Cafe 101		101-413-86010	17.16
	USB-PD-JAN2026	1/26 PD GoTo City Wide Phone Charges		101-415-72030	45.81
	USB-PD-JAN2026	1/26 PD GoTo City Wide Phone Charges		101-416-72030	526.79
	USB-PD-JAN2026	1/26 Internet Subscription		106-413-98040	45.00
	USB-PD-JAN2026	1/26 PD GoTo City Wide Phone Charges		107-422-72030	6.89
	USB-PD-JAN2026	1/26 PD GoTo City Wide Phone Charges		107-422-72030	0.92
	USB-PD-JAN2026	1/26 PD GoTo City Wide Phone Charges		117-416-72030	5.50
	USB-PD-JAN2026	1/26 PD GoTo City Wide Phone Charges		501-406-72030	1.83
	USB-PD-JAN2026	1/26 PD GoTo City Wide Phone Charges		501-406-72030	82.45
	USB-PD-JAN2026	1/26 PD GoTo City Wide Phone Charges		501-503-72030	2.75
	USB-PD-JAN2026	1/26 PD GoTo City Wide Phone Charges		501-503-72030	26.11
	USB-PD-JAN2026	1/26 PD GoTo City Wide Phone Charges		501-508-72030	26.11
	USB-PD-JAN2026	1/26 PD GoTo City Wide Phone Charges		501-508-72030	3.21
	USB-PD-JAN2026	1/26 PD GoTo City Wide Phone Charges		502-406-72030	1.83
	USB-PD-JAN2026	1/26 PD GoTo City Wide Phone Charges		502-406-72030	72.15
	USB-PD-JAN2026	1/26 PD GoTo City Wide Phone Charges		502-510-72030	26.11
	USB-PD-JAN2026	1/26 PD GoTo City Wide Phone Charges		502-510-72030	3.21
	USB-PD-JAN2026	1/26 PD GoTo City Wide Phone Charges		503-406-72030	41.22
	USB-PD-JAN2026	1/26 PD GoTo City Wide Phone Charges		503-406-72030	0.69
	USB-PD-JAN2026	1/26 PD GoTo City Wide Phone Charges		503-520-72030	1.37
	USB-PD-JAN2026	1/26 PD GoTo City Wide Phone Charges		503-520-72030	26.11
	USB-PD-JAN2026	1/26 PD GoTo City Wide Phone Charges		503-521-72030	26.11
	USB-PD-JAN2026	1/26 PD GoTo City Wide Phone Charges		503-521-72030	0.46
	USB-PD-JAN2026	1/26 PD GoTo City Wide Phone Charges		504-406-72030	4.12
	USB-PD-JAN2026	1/26 PD GoTo City Wide Phone Charges		504-406-72030	0.23
	USB-PD-JAN2026	1/26 PD GoTo City Wide Phone Charges		820-610-72030	0.46
	USB-PW-JAN2026	1/26 Flight Light Light Bulbs for Airport		101-435-84050	338.86
	USB-PW-JAN2026	1/26 Sprinkler Warehouse Irrigation Partys		101-440-84050	2,079.75
	USB-PW-JAN2026	1/26 1000 Bulbes Street Light Bulbs		101-440-84077	115.68
	USB-PW-JAN2026	1/26 American Water College D2 Exam Prep N.Griffin		501-508-86010	464.98
	USB-PW-JAN2026	1/26 USPS Gas Sniffer Sent for Repair		502-510-70030	25.25
	USB-PW-JAN2026	1/2 SP CP Supply Co- Gas Tape/Gas Pipe Spray		502-510-70140	1,057.33
	USB-PW-JAN2026-2	1/26 Fresno County Clerk Svcs CEQA Selp Help TTM		101-404-86500	51.15
	USB-PW-JAN2026-2	1/26 Save Mart-Drinks for Emergency Water Leak		501-508-86010	25.53
	USB-PW-JAN2026-2	1/26 Coalinga Me n Eds Food for Emergency Leak		501-508-86010	35.97
80714	2/23/2026	1991	West Hills Machine Shop, Inc.		2,915.06
	051769	2/26 PW Auger Repair		101-440-84077	1,190.33
	051769	2/26 PW Auger Repair		107-422-88100	1,190.33
	052128	2/26 Bollard Material		107-422-70130	256.51

Check Register

Payment Dates: 2/1/2026 - 2/28/2026

Payment Number	Payment Date Payable Number	Vendor # Description	Vendor Name	Account Number	Payment Amount Item Amount
	052128	2/26 Small Trailer Repair		107-422-84060	277.89
80715	2/26/2026	1112	BILLINGSLEY TIRE SERVICE		16.33
	CLG-311392	2/26 PW Tire Repair for #59		501-508-84060	5.45
	CLG-311392	2/26 PW Tire Repair for #59		502-510-84060	5.44
	CLG-311392	2/26 PW Tire Repair for #59		503-521-84060	5.44
80716	2/26/2026	1115	Blais & Associates, Inc.		6,044.66
	BA_9473_2026	2/26 Grant Svcs for DroughtRelief/Turf Replacement		501-503-98471	929.50
	BA_9473_2026	2/26 Grant Svcs for DroughtRelief/Turf Replacement		501-508-98472	929.50
	BA_9474_2026	2/26 Urban Community Forest Program Grant Suppo		306-422-98850	1,310.66
	BA_9499_2026	2/26 Grant Research & Support Jan 2026		501-508-88130	958.34
	BA_9499_2026	2/26 Grant Research & Support Jan 2026		502-510-88130	958.33
	BA_9499_2026	2/26 Grant Research & Support Jan 2026		503-521-88130	958.33
80717	2/26/2026	02020	Boot Barn		200.00
	INV00568815	2/26 PW Boots- B. Arballo		101-440-62080	200.00
80718	2/26/2026	02504	Brian Corley		3,372.27
	26-021101	2/26 WP Troubleshoot Blower		501-503-84020	1,215.87
	26-021601	2/26 PW Tested Failed Pumps		503-521-84020	2,156.40
80719	2/26/2026	02594	CINTAS CORPORATION #3		1,418.99
	425167983	2/26 BLDG Employee Uniforms/Sanitary Supplies/M		101-404-70100	13.06
	425167983	2/26 SC Employee Uniforms/Sanitary Supplies/Mats		101-431-70100	45.37
	425167983	2/26 ADM Employee Uniforms/Sanitary Supplies/Ma		101-432-84030	369.56
	425167983	2/26 MG Employee Uniforms/Sanitary Supplies/Mat		101-440-70100	85.76
	425167983	2/26 GT Employee Uniforms/Sanitary Supplies/Mats		107-422-70100	52.81
	425167983	2/26 WTP Employee Uniforms/Sanitary Supplies/Ma		501-503-70100	58.89
	425167983	2/26 MR Employee Uniforms/Sanitary Supplies/Mat		501-508-70100	23.34
	425167983	2/26 WD Employee Uniforms/Sanitary Supplies/Mat		501-508-70100	52.81
	425167983	2/26 GE Employee Uniforms/Sanitary Supplies/Mats		502-510-70100	52.81
	425167983	2/26 MR Employee Uniforms/Sanitary Supplies/Mat		502-510-70100	23.34
	425167983	2/26 WWTP Employee Uniforms/Sanitary Supplies/		503-520-70100	27.36
	425167983	2/26 WWC Employee Uniforms/Sanitary Supplies/M		503-521-70100	52.81
	4259930003	2/26 BLDG Employee Uniforms/Sanitary Supplies/M		101-404-70100	13.06
	4259930003	2/26 SC Employee Uniforms/Sanitary Supplies/Mats		101-431-70100	45.37
	4259930003	2/26 ADM Employee Uniforms/Sanitary Supplies/Ma		101-432-84030	72.71
	4259930003	2/26 MG Employee Uniforms/Sanitary Supplies/Mat		101-440-70100	85.76
	4259930003	2/26 GT Employee Uniforms/Sanitary Supplies/Mats		107-422-70100	52.81
	4259930003	2/26 WTP Employee Uniforms/Sanitary Supplies/Ma		501-503-70100	58.89
	4259930003	2/26 WD Employee Uniforms/Sanitary Supplies/Mat		501-508-70100	52.81
	4259930003	2/26 MR Employee Uniforms/Sanitary Supplies/Mat		501-508-70100	23.34
	4259930003	2/26 MR Employee Uniforms/Sanitary Supplies/Mat		502-510-70100	23.34
	4259930003	2/26 GE Employee Uniforms/Sanitary Supplies/Mats		502-510-70100	52.81
	4259930003	2/26 WWTP Employee Uniforms/Sanitary Supplies/		503-520-70100	27.36
	4259930003	2/26 WWC Employee Uniforms/Sanitary Supplies/M		503-521-70100	52.81
80721	2/26/2026	02598	CINTAS CORPORATION NO. 2		258.63
	5319222209	2/26 PW First Aid Kit Supply Refill		101-413-88100	141.10
	5319222209	2/26 PW First Aid Kit Supply Refill		101-432-84030	8.21
	5319222209	2/26 PW First Aid Kit Supply Refill		503-521-70440	66.66
	5319222210	2/26 PW First Aid Kit Refill		101-431-70150	42.66
80722	2/26/2026	1224	COALINGA HARDWARE		201.08
	839518	2/26 FD Leaf Blower		101-416-84050	97.29
	839590	2/26 PW Pick for Truck #69		503-521-70140	40.36
	839591	2/26 PW Rope/ Water Nozzle		101-440-70060	57.93
	839818	2/26 Bolts for Coming Soon Sign		101-415-98020	5.50

Check Register

Payment Dates: 2/1/2026 - 2/28/2026

Payment Number	Payment Date Payable Number	Vendor # Description	Vendor Name	Account Number	Payment Amount Item Amount
80723	2/26/2026 189849	02787 2/26 PD Code Enforcement	Data Ticket, Inc.	101-413-88100	250.00 250.00
80724	2/26/2026 SIP-E228527	02289 2/26 PW Rectifier Cell Data Feb. 2026	Elecsys International, LLC	502-510-72030	156.00 156.00
80725	2/26/2026 0193244-IN	1336 2/26 PD Badges	Entenmann-Rovin Company	101-413-70101	430.76 430.76
80726	2/26/2026 120525-A	02660 2/26 WP New Flooring for Control Room	Expert Painting and Coatings	501-503-84030	4,980.00 4,980.00
80727	2/26/2026 374569	1402 2/26 PW Service Center	Fresno County Department of Public Health	101-431-92090	133.00 133.00
80728	2/26/2026 9806830908 9806830908 9806830908	1445 2/26 PW Paper Towels/Paper Towel Dispenser 2/26 PW Paper Towels/Paper Towel Dispenser 2/26 PW Paper Towels/Paper Towel Dispenser	GRAINGER	501-508-84030 502-510-84030 503-521-84030	216.63 72.21 72.21 72.21
80729	2/26/2026 3138818	1446 2/26 WP Material for Drying Beds	Granite Construction Company	503-520-70140	552.32 552.32
80730	2/26/2026 21871 21872 21873 21874 21875 21876 21876 21877 21878 21879 21880 21881 21882 21883 21884	1450 1/26 154 Buchanan St. General Abatement 1/26 325 E Houston City Attorney Fees 1/26 725 S Monterey Ave City Attorney Fees 1/26 City Clerk City Attorney Fees 1/26 City Council City Attorney Fees 1/25 City Manager City Attorney Fees 1/25 City Manager City Attorney Fees (Fire Damage) 1/26 City Services Attorney Fees (Water Plant) 1/26 COC VS Juan Lomeli City Attorney Fees 1/26 DG Construction vs COC Attorney Fees 1/26 Employment Matter (Cano) City Attorney Fees 1/26 HR City Attorney Fees 1/26 Labor Relations City Attorney Fees 1/26 Police Department City Attorney Fees 1/26 People vs John Apple EtAl City Attorney Fees	Griswold, LaSalle, Cobb, Dowd, and Gin, LLP	101-401-88010 101-401-88010 101-401-88010 101-401-88010 101-401-88010 101-401-88010 101-404-77440 501-503-88010 101-401-88010 101-401-88010 101-401-88010 101-401-88010 101-401-88010 101-401-88010 101-401-88010	22,989.34 115.42 38.75 122.65 804.79 3,635.35 2,462.07 1,826.17 255.00 133.75 1,140.83 9,085.75 552.50 1,678.75 416.56 721.00
80731	2/26/2026 INV29023	02856 2/26 PW Street Sweeper Rental	Haaker Equipment Company	504-535-88100	13,801.88 13,801.88
80732	2/26/2026 0014706	03134 2/26 260 Walker Ln Turf Replacement Program	JUDITH FERNANDEZ	501-503-98471	2,173.50 2,173.50
80733	2/26/2026 72709	1565 2/26 Coming Soon Sign for Animal Shelter	KRC Safety Co., Inc.	101-415-98020	568.37 568.37
80734	2/26/2026 INV1039095	02626 2/26 FD PPE Boots	L.N. Curtis and Sons	101-416-70102	669.70 669.70
80735	2/26/2026 116226 116227	1661 2/26 PW Pest Control Services 2/26 FD Pest Control Services	Mountain Valley Pest Control, Inc.	503-521-84030 101-416-84050	63.00 35.00 28.00
80736	2/26/2026 907397830 907397830 907397830 907426379	1686 2/26 PW Gloves 2/26 PW Gloves 2/26 PW Gloves 2/26 PW Tyvek Coverhalls	Northern Safety Co., Inc.	501-508-70101 502-510-70101 503-521-70101 503-521-70101	704.33 72.54 72.53 72.53 486.73
80737	2/26/2026 4316-151594	1692 2/26 PD Filter/Oil Prius 1	O'Reilly Automotive, Inc.	101-413-84060	508.34 75.62

Check Register

Payment Dates: 2/1/2026 - 2/28/2026

Payment Number	Payment Date Payable Number	Vendor # Description	Vendor Name	Account Number	Payment Amount Item Amount
	4316-151600	2/26 PW Service Truck Supplies #59		101-431-84060	92.88
	4316-151709	2/26 PW Stock Wiper Fld		101-431-70150	11.97
	4316-152425	2/26 FD M255 Oil/Filter		117-416-84060	81.62
	4316-152486	2/26 PW Oil Change for #59		501-508-84060	20.68
	4316-152486	2/26 PW Oil Change for #59		502-510-84060	20.67
	4316-152486	2/26 PW Oil Change for #59		503-521-84060	20.67
	4316-152586	2/26 PW Oil Change for #111		501-508-84060	41.00
	4316-152586	2/26 PW Oil Change for #111		502-510-84060	41.00
	4316-152586	2/26 PW Oil Change for #111		503-521-84060	41.00
	4316-152629	2/26 PW Oil Change for #70		101-440-84060	30.62
	4316-152629	2/26 PW Oil Change for #70		107-422-84060	30.61
80738	2/26/2026	1721	PG&E		116.68
	0014708	2/26 Cambridge/Elm Signal (9389051722-5) Jan 202		110-424-72021	116.68
80739	2/26/2026	1722	PG&E 1533-5		94,584.82
	0014707	7053841037 7th & Elm Firehouse Horn		101-416-72020	93.28
	0014707	7053841272 300 W Elm Fire Station Lights		101-416-72020	2,261.81
	0014707	7059439736 Retrolift Loan Program Charges		101-416-96057	629.64
	0014707	7053841516 Police Station/ Jail/ City Hall		101-432-72020	6,337.80
	0014707	795617993 240 N 6th St		101-432-72020	937.38
	0014707	7052222061 270 S 6th St		101-432-72020	48.23
	0014707	7053662501 Retrofit Loan Program Charges City/PD		101-432-96057	1,188.22
	0014707	7053841771 27500 Phelps Ave Ste 1LargeAirportHan		101-435-72020	29.90
	0014707	7053841565 NW Cor Phelps Airport Lights		101-435-72020	766.01
	0014707	7053841899 27500 Phelps Ave Ste 19 Airport Hange		101-435-72020	121.96
	0014707	7054189141 Sunset & 5th Ave		101-440-72011	380.21
	0014707	7053841921 Sunset & Washington-Wtr Ftn		101-440-72011	25.46
	0014707	7053841936 408 S Fifth Lynch Park		101-440-72011	12.27
	0014707	7053841050 5th Cedar St Tower Clock		101-440-72011	53.19
	0014707	7053841177 300 Coalinga Plaza		110-424-72021	30.07
	0014707	7053841881 140 E Durian Parking Lot Lights		110-424-72021	23.18
	0014707	7053841990 160 W Elm		110-424-72021	22.28
	0014707	7053841014 160 W Elm INTRNL ARPT 3144 Term Bld		110-424-72021	22.28
	0014707	7053986207 Warthan Place Ph2		110-424-72021	13.14
	0014707	7053841661 Forest 7 Fifith		110-424-72021	13.58
	0014707	7053841694 160 W Elm		110-424-72021	33.43
	0014707	3443128775 TR 5208 Spano Ent Posa Chanet Estate		110-424-72021	12.76
	0014707	7053841023 Monterey & Tyler Clock		110-424-72021	12.50
	0014707	3443128411 TR5208 Spano Ent Posa Chanet 3		110-424-72021	117.20
	0014707	7053841485 Washington & Fresno		110-424-72021	10.23
	0014707	7058903139 Tache Way & Warthan St		110-424-72021	19.33
	0014707	7053841501 410 El Rancho Blvd		110-424-72021	34.26
	0014707	2/7053841308 Van Ness & Elm		110-424-72021	65.83
	0014707	7053841538 160 W Elm Street Light InventoryProjec		110-424-72021	49.60
	0014707	7053841913 N/S Valley (Streetlights)		110-424-72021	51.01
	0014707	3443128611 TR 4492 FoxHallow II Ph2 Forest/Cox		110-424-72021	51.05
	0014707	7054548044 Cooldige N Hachman		110-424-72021	10.20
	0014707	7053841536 160 W Elm Street Light InventoryProjec		110-424-72021	101.33
	0014707	7050256422 6th & Durian		110-424-72021	102.33
	0014707	7053841534 160 W Elm Street Light InventoryProjec		110-424-72021	102.69
	0014707	3443128372 TR 5246PH1 Stallion Springs Sac& Fores		110-424-72021	56.08
	0014707	7055180510 Forest Ave Btwn 3rd st & 5th st		110-424-72021	57.99
	0014707	3249826069 TR 4492 Fox Hallow II		110-424-72021	76.58
	0014707	7053841379 Polk & Forest Ave		110-424-72021	80.01
	0014707	7053841535 160 W Elm Street Light InventoryProjec		110-424-72021	80.06
	0014707	7053841848 SE Juniper Ridge Sprinklers		110-424-72021	34.61
	0014707	7051816617 Jayne Ave Willow Springs		110-424-72021	110.71
	0014707	7053841439 Phelps & La Cuesta		110-424-72021	12.02
	0014707	7058160009 N/S of Phelps Ave (W of Posa Chanet)		110-424-72021	151.11

Check Register

Payment Dates: 2/1/2026 - 2/28/2026

Payment Number	Payment Date Payable Number	Vendor # Description	Vendor Name	Account Number	Payment Amount Item Amount
0014707		7053841505 Cambridge & Elm Hwy 198		110-424-72021	287.40
0014707		7053841008 160 W Elm INTRNL ARPT 3144 Term Bld		110-424-72021	3,071.22
0014707		7053841157 240 W Elm Storage Building		110-424-72021	516.70
0014707		7053841429 TRACT 5339 Dorothy Allen Estates		110-424-72021	404.53
0014707		7053841555 TR 5451 Warthen Meadows		110-424-72021	883.03
0014707		7053841004 160 W Elm INTRNL ARPT 3144 Term Bld		110-424-72021	169.82
0014707		7053841022 160 W Elm INTRNL 3144 Term Bldg		110-424-72021	161.49
0014707		7053841397 Cambridge & Elm/Hwy 198		110-424-72021	160.92
0014707		329090333 260 1/2 Cambridge Ave		110-424-72021	242.33
0014707		7053841253 Cambridge & Joaquin		110-424-72021	216.99
0014707		7053841244 TR 5344 Promontory Point		110-424-72021	211.16
0014707		3443128041 TR 5246 Phase 2 Stallion SpringsSac/For		110-424-72021	150.46
0014707		7053841909 200 El Rancho Blvd Irrigation Controls		110-424-72021	10.19
0014707		7053841026 160 W ELM INTRNL ARPT 3144 Term Bldg		110-424-72021	309.01
0014707		7053841619 Monterey & Tyler		110-424-72021	10.19
0014707		7053841204 SE Corner of First & Forest Landscaping		110-424-72021	10.19
0014707		7053841842 350 El Rancho Blvd- Irrigation Control		110-424-72021	10.19
0014707		7053841791 745 W Forest Ave Landscape Pedestal		110-424-72021	10.19
0014707		7053841365 Longhallow & Echo Canyon		110-424-72021	29.41
0014707		7053841349 160 W ELM		110-424-72021	25.53
0014707		7050007234 Coolidge N Hachman		110-424-72021	10.20
0014707		1638874976 25 1/2 W Polk		110-424-72021	146.02
0014707		705341016 160 W Elm INTRNL ARPT 3144 Term Bldg		110-424-72021	953.28
0014707		7053841002 160 W Elm INTRNL ARPT 3144 Term Bld		110-424-72021	1,122.76
0014707		9713313248 25 1/2 W PolkTraffic Control		110-424-72021	129.07
0014707		3443128925 TR 5140 Sandalwood Jayne/WillowSpri		110-424-72021	137.69
0014707		7055365996 Elm 7 Second		110-424-72021	139.69
0014707		3443128591 City Sunset St Project PM#30257800		110-424-72021	104.42
0014707		7053841206 Cor Psa Chnt & San Sm Lift Station		110-424-72021	10.19
0014707		7053841979 City Yard		110-424-72021	332.38
0014707		7053841131 SW Cor Gale & Derrick Water Mtr		501-503-72020	10.19
0014707		7053841518 NW NW 31 20 16 Chlorine Booster		501-503-72020	26.17
0014707		7056027714 NE 11 20 15		501-503-72020	141.29
0014707		7053841036 NE SW 26 19 15 Booster Station		501-503-72020	3,288.07
0014707		7053841171 SW SW 7 20 15 Booster Sta		501-503-72020	595.47
0014707		7054838556 25034 Palmer Ave		501-503-72020	47,800.05
0014707		7053841615 SW SW SW 18 20 16 -Reservoir		501-503-72020	30.42
0014707		7053841864 NW SW 31 20 15 Wtr Control Circuit		501-503-72020	34.91
0014707		7053841684 NW NW 11 20 15 Wtr Dept		501-503-72020	48.62
0014707		7054291414 Retrofit Loan 135 E Sacramento		501-508-72020	46.51
0014707		7053841979 City Yard		501-508-72020	332.38
0014707		7054291414 Retrofit Loan 135 E Sacramento		502-510-72020	45.14
0014707		7053841979 City Yard		502-510-72020	332.38
0014707		7053841697 Baker Alley Btwn Buch/Lin		502-510-72020	10.19
0014707		7053841066 NE Corner Harvard College		502-510-72020	34.41
0014707		7053841312 Thompson Btwn Valley/Polk		502-510-72020	55.98
0014707		7053841243 Pine Alley Btwn Roosevelt/AR		502-510-72020	93.85
0014707		7053841361 Alley S Pleasant & E Warthan AlleyLight		502-510-72020	71.31
0014707		7053841574 Coalinga Allery Btwn Mad/Monterey		502-510-72020	70.42
0014707		7053841123 Cherry Ln E of Elm		502-510-72020	103.71
0014707		7053841358 College Alley S Side Cat Pro 611College		502-510-72020	65.52
0014707		7053841657 Behind 595 Roosevelt Alley Light		502-510-72020	65.27
0014707		7053841102 N end of Maple St		502-510-72020	63.70
0014707		7053841783 California Alley N of Harvard		502-510-72020	84.32
0014707		7053841466 Fres Aly btwn Tyler/Polk		502-510-72020	10.19
0014707		7052100780 NE SE 33 20 15 WWP		503-520-72020	13,740.40
0014707		7056603692 SE 33 20 15 Sewer Treatment Palnt		503-520-72020	1,946.22
0014707		7054291414 Retrofit Loan 135 E Sacramento		503-521-72020	45.14
0014707		7053841979 City Yard		503-521-72020	332.38

Check Register

Payment Dates: 2/1/2026 - 2/28/2026

Payment Number	Payment Date Payable Number	Vendor # Description	Vendor Name	Account Number	Payment Amount Item Amount
	0014707	7053841194 Sewer Lift Pump Echo		503-521-72020	249.08
	0014707	7053841328 Sewer Lift Station P/L		503-521-72020	157.92
	0014707	7053841845 Sewer Lift Station/Pol		503-521-72020	179.03
	0014707	7053841367 Sewer Lift Station / Kim		503-521-72020	54.72
80747	2/26/2026	02985	PRECISION CIVIL ENGINEERING		1,812.50
	33195	2/26 Outdoor Food Court		101-404-98025	370.00
	33196	2/26 Momentum Tactical Admin Site Plan Review		101-404-86500	240.00
	33198	2/26 Senior Apts (Elm/Locust)		101-404-86500	1,202.50
80748	2/26/2026	1772	Robert Arthurton		11,807.48
	IHCM31209	2/26 Animal Shelter Fence		101-415-98020	11,807.48
80749	2/26/2026	1843	SIRCHIE ACQUISITION COMPANY LLC		180.17
	0705739-IN	2/26 PD Evidence Supplies		101-413-70440	142.73
	0714750-IN	2/26 PD Evidence Supplies		101-413-70440	37.44
80750	2/26/2026	03135	SOUND CONTRACTING INC.		25,538.17
	5803	2/26 Council Chambers A/V Modernization 50%Dep		141-422-98985	25,538.17
80751	2/26/2026	1898	Telstar Instruments, Inc.		12,411.99
	130681	2/26 WP Annual Maintenance		501-503-84020	12,411.99
80752	2/26/2026	1902	Thatcher Company, Inc.		6,592.21
	2026250100477	2/26 WP Chemical Chlorine Refund (2026250900107		501-503-70230	-2,000.00
	2026250100477	2/26 WP Chemical Chlorine		501-503-70230	8,592.21
80753	2/26/2026	02846	T-MOBILE USA INC		189.51
	0014709	383-4514 WP Primary 100%		501-503-72030	39.69
	0014709	307-0123 Mobile Internet 100%		501-503-72030	31.00
	0014709	307-0123 Mobile Internet 100%		501-503-72030	31.00
	0014709	341-9613 WP On-Call 100%		501-503-72030	43.91
	0014709	362-6567 Field Supervisor 50% - Uribe		501-503-72030	21.96
	0014709	362-6567 Field Supervisor 50% - Uribe		503-520-72030	21.95
80754	2/26/2026	02846	T-MOBILE USA INC		1,105.99
	0014712	559-307-0079 Mobile Internet B171 Ipad		101-416-72030	21.34
	0014712	559-931-3881		101-416-72030	10.00
	0014712	559-929-2286 Ipad BR371		101-416-72030	10.00
	0014712	559-403-3702 Mobile INternet Fire Chief Tablet		101-416-72030	21.34
	0014712	559-403-5177 Mobile Internet Prevention Tablet		101-416-72030	21.34
	0014712	559-764-0418 IPADB172		101-416-72030	21.34
	0014712	559-929-2524 Ipad E171		101-416-72030	10.00
	0014712	559-764-0427 IPAD E171		101-416-72030	21.34
	0014712	559-929-6850 Ipad B173		101-416-72030	10.00
	0014712	559-929-2285 Ipad B172		101-416-72030	10.00
	0014712	559-307-0077 Mobile Internet E171/L171 Ipad		101-416-72030	21.34
	0014712	559-307-0078 Mobile Internet C170 Ipad		101-416-72030	21.34
	0014712	559-764-0421 IPAD BR371		101-416-72030	21.34
	0014712	559-601-6245 M.Soto		101-416-72030	44.15
	0014712	559-764-0429 IPAD B173		101-416-72030	21.34
	0014712	559-601-9391 J. Milligan		101-416-72030	44.15
	0014712	559-403-5436 G. DuPuis		101-416-72030	44.15
	0014712	559-307-0058 Mobile Internet M252		101-416-72030	33.00
	0014712	559-307-0067 Mobile INternet M254		101-416-72030	33.00
	0014712	559-601-9658 Mobile Internet M252		101-416-72030	44.15
	0014712	559-307-0066 Mobile Internet M256		101-416-72030	33.00
	0014712	Past Due FD T-Mobile Cell Phone (996314500)		101-416-72030	173.48
	0014712	559-307-0065 Mobile Internet L171		101-416-72030	33.00
	0014712	559-307-0069 Mobile Internet Engine 172		101-416-72030	33.00
	0014712	559-307-0068 Mobile Internet E171		101-416-72030	33.00
	0014712	559-307-0059 Mobile Internet M255		101-416-72030	33.00

Check Register

Payment Dates: 2/1/2026 - 2/28/2026

Payment Number	Payment Date Payable Number	Vendor # Description	Vendor Name	Account Number	Payment Amount Item Amount
	0014712	559-929-6850		101-416-72030	21.34
	0014712	559-929-2524		101-416-72030	21.34
	0014712	559-929-2286		101-416-72030	21.34
	0014712	559-929-2285 IPAD		101-416-72030	21.34
	0014712	559-764-0439 IPAD		101-416-72030	21.34
	0014712	559-307-0070 Mobile Internet Brush 371		101-416-72030	33.00
	0014712	559-601-9359 K. Krider		101-416-72030	44.15
	0014712	559-307-0072 Mobile Internet Patrol 172		101-416-72030	33.00
	0014712	559-307-0057 Mobile Internet M251		101-416-72030	33.00
	0014712	559-307-0060 Mobile Internet M253		101-416-72030	33.00
80757	2/26/2026	02351	Tractor Supply Company		164.99
	103804	2/26 PW Shop Propane		101-431-70150	29.70
	104895	2/26 PW Pressure Washer Parts for Wash Rack		501-508-84030	5.45
	104895	2/26 PW Pressure Washer Parts for Wash Rack		502-510-84030	5.44
	104895	2/26 PW Pressure Washer Parts for Wash Rack		503-521-84030	5.44
	200099305	2/26 PW Propane for Shop		101-431-70150	31.79
	200101448	2/26 PW Spray Gun		101-440-84050	43.58
	200101448	2/26 PW Spray Gun		107-422-84050	43.59
80758	2/26/2026	1935	Tri City Engineering		1,747.50
	3121-03	2/26 SRTS Engineering Support		107-422-88130	800.00
	3131-01	2/26 Resurfacing Street Project Ph .3		125-422-98401	947.50
80759	2/26/2026	1944 CC	US Bank Corporate Payment Center		1,197.05
	USB-FD-JAN2026-7	1/26 Cal Training I Rodriguez- Annual Symposium		101-416-75030	625.00
	USB-FD-JAN2026-7	1/26 Expedia I.Rodriguez Training 6/01-6/04		101-416-75030	546.62
	USB-FD-JAN2026-7	1/26 Elite Command Training - I. Rodriguez		101-416-75030	470.00
	USB-FD-JAN2026-7	1/26 Expedia Refund		101-416-75030	-522.93
	USB-FD-JAN2026-7	1/26 Big 5 Misc Training Items		101-416-84070	41.36
	USB-FD-JAN2026-7	1/26 FSP Health Edu 1 BLS eCard		117-416-86040	37.00
80760	2/26/2026	1964	USABluebook		102.16
	INV00955987	2/26 WP Lab Supplies		501-503-70202	64.50
	INV00958706	2/26 WP Lab Supplies		501-503-70202	37.66
80761	2/26/2026	02864	VESTIS GROUP INC ARAMARK UNIFORM & APPAREL LLC		541.14
	5031688201	2/26 PD Jail Blankets		101-413-70380	541.14
80762	2/26/2026	1991	West Hills Machine Shop, Inc.		1,479.50
	052256	2/26 PW Lift Station Spool Discharge Pipe		503-521-70140	1,479.50
80763	2/26/2026	1993	West Hills Oil, Inc.		4,252.38
	307855	2/26 FD Fuel for Generator		101-416-70160	448.10
	85011	2/26 WP Fuel for December 2025		501-503-70160	1,369.78
	85011	2/26 WP Fuel for December 2025		503-520-70160	342.45
	85230	2/26 WP Fuel for Jan 2026		501-503-70160	1,673.64
	85230	2/26 WP Fuel for Jan 2026		503-520-70160	418.41
80764	2/26/2026	2002	Wittman Enterprises, LLC		1,986.83
	202601-C1785	2/26 FD January Amb Billing		117-416-75040	1,986.83
DFT0009754	2/13/2026	1025	AFLAC Group Insurance		461.74
	0014557	AFLAC After Tax		950-000-34600	461.74
DFT0009755	2/13/2026	1025	AFLAC Group Insurance		1,458.51
	0014558	AFLAC Pre Tax		950-000-34600	1,458.51
DFT0009773	2/13/2026	02043	New York Life Insurance		659.27
	0014581	New York Life Insurance		950-000-32400	659.27
DFT0009791	2/13/2026	1207	City of Coalinga		600.25
	0014604	Unreimbursed Medical		950-000-34500	600.25

Check Register

Payment Dates: 2/1/2026 - 2/28/2026

Payment Number	Payment Date Payable Number	Vendor # Description	Vendor Name	Account Number	Payment Amount Item Amount
DFT0009792	2/13/2026 0014626	1677 457 Newport \$\$ General	Newport Trust Company	950-000-32100	90.00 90.00
DFT0009793	2/13/2026 0014627	1677 457 Newport \$\$ General	Newport Trust Company	950-000-32100	302.17 302.17
DFT0009794	2/13/2026 0014628	1677 457 Newport \$\$ General	Newport Trust Company	950-000-32100	877.89 877.89
DFT0009795	2/13/2026 0014629	1677 457 Newport \$\$ General	Newport Trust Company	950-000-32100	37.50 37.50
DFT0009796	2/13/2026 0014630	1677 457 Newport \$\$ General	Newport Trust Company	950-000-32100	448.89 448.89
DFT0009797	2/13/2026 0014631	1677 457 Newport \$\$ General	Newport Trust Company	950-000-32100	114.43 114.43
DFT0009798	2/13/2026 0014632	1677 457 Newport \$\$ General	Newport Trust Company	950-000-32100	75.00 75.00
DFT0009799	2/13/2026 0014633	1677 457 Newport \$\$ General	Newport Trust Company	950-000-32100	75.00 75.00
DFT0009800	2/13/2026 0014634	1677 457 Newport % General	Newport Trust Company	950-000-32100	433.01 433.01
DFT0009801	2/13/2026 0014635	1677 457 Newport % General	Newport Trust Company	950-000-32100	623.73 623.73
DFT0009802	2/13/2026 0014636	1677 457 Newport % General	Newport Trust Company	950-000-32100	173.59 173.59
DFT0009803	2/13/2026 0014637	1677 457 Newport % General	Newport Trust Company	950-000-32100	668.96 668.96
DFT0009804	2/13/2026 0014638	1677 457 Newport % General	Newport Trust Company	950-000-32100	537.97 537.97
DFT0009805	2/13/2026 0014639	1677 457 Newport % General	Newport Trust Company	950-000-32100	155.04 155.04
DFT0009806	2/13/2026 0014640	1677 457 Newport % General	Newport Trust Company	950-000-32100	607.00 607.00
DFT0009807	2/13/2026 0014641	1677 457 Newport % General	Newport Trust Company	950-000-32100	408.87 408.87
DFT0009808	2/13/2026 0014642	1677 457 Newport % General	Newport Trust Company	950-000-32100	708.32 708.32
DFT0009809	2/13/2026 0014643	1677 457 Newport % General	Newport Trust Company	950-000-32100	145.67 145.67
DFT0009810	2/13/2026 0014644	1677 457 Newport % General	Newport Trust Company	950-000-32100	310.94 310.94
DFT0009811	2/13/2026 0014645	1677 457 Newport % General	Newport Trust Company	950-000-32100	324.30 324.30
DFT0009812	2/13/2026 0014646	1677 457 Newport % General	Newport Trust Company	950-000-32100	158.80 158.80
DFT0009813	2/13/2026 0014647	1677 457 Newport % General	Newport Trust Company	950-000-32100	349.97 349.97

Check Register

Payment Dates: 2/1/2026 - 2/28/2026

Payment Number	Payment Date Payable Number	Vendor # Description	Vendor Name	Account Number	Payment Amount Item Amount
DFT0009814	2/13/2026 0014648	1677 457 Newport EE\$/ER%	Newport Trust Company	950-000-32100	638.56 638.56
DFT0009815	2/13/2026 0014649	1677 457 Newport EE\$/ER%	Newport Trust Company	950-000-32100	2,215.11 2,215.11
DFT0009816	2/13/2026 0014653	1869 SDU Fresno County DCSS	California State Disbursement Unit	950-000-34010	315.69 315.69
DFT0009817	2/13/2026 0014654	1869 SDU Fresno County DCSS	California State Disbursement Unit	950-000-34010	109.61 109.61
DFT0009818	2/13/2026 0014655	1869 SDU Merced County DCSS	California State Disbursement Unit	950-000-34010	269.53 269.53
DFT0009819	2/13/2026 0014656	02078 SDI	SDI	950-000-31500	4,447.76 4,447.76
DFT0009820	2/13/2026 0014657	02077 SDI Mgr	SDI (Mgr)	950-000-31500	353.04 353.04
DFT0009821	2/13/2026 0014658	1331 State W/H	Employment Development Dept. (EDD)	950-000-31200	10,930.33 10,930.33
DFT0009822	2/13/2026 0014659 0014659 0014659	1956 Fed W/H Social Security Medicare	IRS/United States Treasury	950-000-31100 950-000-31300 950-000-31400	81,887.34 26,229.24 45,108.54 10,549.56
DFT0009866	2/27/2026 0014715	1025 AFLAC After Tax	AFLAC Group Insurance	950-000-34600	461.74 461.74
DFT0009867	2/27/2026 0014716	1025 AFLAC Pre Tax	AFLAC Group Insurance	950-000-34600	1,458.51 1,458.51
DFT0009885	2/27/2026 0014739	02043 New York Life Insurance	New York Life Insurance	950-000-32400	659.27 659.27
DFT0009903	2/27/2026 0014762	1207 Unreimbursed Medical	City of Coalinga	950-000-34500	600.25 600.25
DFT0009904	2/27/2026 0014784	1677 457 Newport \$\$ General	Newport Trust Company	950-000-32100	90.00 90.00
DFT0009905	2/27/2026 0014785	1677 457 Newport \$\$ General	Newport Trust Company	950-000-32100	302.17 302.17
DFT0009906	2/27/2026 0014786	1677 457 Newport \$\$ General	Newport Trust Company	950-000-32100	942.00 942.00
DFT0009907	2/27/2026 0014787	1677 457 Newport \$\$ General	Newport Trust Company	950-000-32100	37.50 37.50
DFT0009908	2/27/2026 0014788	1677 457 Newport \$\$ General	Newport Trust Company	950-000-32100	448.89 448.89
DFT0009909	2/27/2026 0014789	1677 457 Newport \$\$ General	Newport Trust Company	950-000-32100	114.43 114.43
DFT0009910	2/27/2026 0014790	1677 457 Newport \$\$ General	Newport Trust Company	950-000-32100	75.00 75.00
DFT0009911	2/27/2026 0014791	1677 457 Newport \$\$ General	Newport Trust Company	950-000-32100	75.00 75.00

Check Register

Payment Dates: 2/1/2026 - 2/28/2026

Payment Number	Payment Date Payable Number	Vendor # Description	Vendor Name	Account Number	Payment Amount Item Amount
DFT0009912	2/27/2026 0014792	1677 457 Newport % General	Newport Trust Company	950-000-32100	433.01 433.01
DFT0009913	2/27/2026 0014793	1677 457 Newport % General	Newport Trust Company	950-000-32100	775.58 775.58
DFT0009914	2/27/2026 0014794	1677 457 Newport % General	Newport Trust Company	950-000-32100	173.59 173.59
DFT0009915	2/27/2026 0014795	1677 457 Newport % General	Newport Trust Company	950-000-32100	411.71 411.71
DFT0009916	2/27/2026 0014796	1677 457 Newport % General	Newport Trust Company	950-000-32100	619.18 619.18
DFT0009917	2/27/2026 0014797	1677 457 Newport % General	Newport Trust Company	950-000-32100	155.04 155.04
DFT0009918	2/27/2026 0014798	1677 457 Newport % General	Newport Trust Company	950-000-32100	580.72 580.72
DFT0009919	2/27/2026 0014799	1677 457 Newport % General	Newport Trust Company	950-000-32100	391.69 391.69
DFT0009920	2/27/2026 0014800	1677 457 Newport % General	Newport Trust Company	950-000-32100	719.42 719.42
DFT0009921	2/27/2026 0014801	1677 457 Newport % General	Newport Trust Company	950-000-32100	145.67 145.67
DFT0009922	2/27/2026 0014802	1677 457 Newport % General	Newport Trust Company	950-000-32100	387.21 387.21
DFT0009923	2/27/2026 0014803	1677 457 Newport % General	Newport Trust Company	950-000-32100	326.98 326.98
DFT0009924	2/27/2026 0014804	1677 457 Newport % General	Newport Trust Company	950-000-32100	158.80 158.80
DFT0009925	2/27/2026 0014805	1677 457 Newport % General	Newport Trust Company	950-000-32100	351.53 351.53
DFT0009926	2/27/2026 0014806	1677 457 Newport EE\$/ER%	Newport Trust Company	950-000-32100	638.56 638.56
DFT0009927	2/27/2026 0014807	1677 457 Newport EE\$/ER%	Newport Trust Company	950-000-32100	2,215.11 2,215.11
DFT0009928	2/27/2026 0014811	1869 SDU Fresno County DCSS	California State Disbursement Unit	950-000-34010	315.69 315.69
DFT0009929	2/27/2026 0014812	1869 SDU Fresno County DCSS	California State Disbursement Unit	950-000-34010	109.61 109.61
DFT0009930	2/27/2026 0014813	1869 SDU Merced County DCSS	California State Disbursement Unit	950-000-34010	269.53 269.53
DFT0009931	2/27/2026 0014814	02078 SDI	SDI	950-000-31500	4,359.81 4,359.81
DFT0009932	2/27/2026 0014815	02077 SDI Mgr	SDI (Mgr)	950-000-31500	360.84 360.84
DFT0009933	2/27/2026 0014816	1331 State W/H	Employment Development Dept. (EDD)	950-000-31200	10,785.99 10,785.99

Check Register

Payment Dates: 2/1/2026 - 2/28/2026

Payment Number	Payment Date Payable Number	Vendor # Description	Vendor Name	Account Number	Payment Amount Item Amount
DFT0009934	2/27/2026	1956	IRS/United States Treasury		81,920.97
	0014817	Fed W/H		950-000-31100	27,177.47
	0014817	Social Security		950-000-31300	44,367.34
	0014817	Medicare		950-000-31400	10,376.16
					Grand Total: 1,403,313.98

Report Summary

Fund Summary

Fund	Payment Amount
101 - GENERAL FUND	400,003.25
105 - COPS GRANT FUND	18,078.27
106 - POLICE DEPT GRANTS	26,437.88
107 - GAS TAX FUND	10,258.62
110 - LTF - ARTICLE 8 FUND	11,758.76
111 - SB1-ROAD REHAB MAINT ACCT FUND	695.00
117 - IGT-INTERGOVERNMENTAL TRANSFER	37,053.94
125 - MEASURE C-STREET MAINTENANCE	947.50
126 - MEASURE C-ADA COMPLIANCE	4,220.00
127 - MEASURE C-FLEXIBLE FUNDING	1,746.25
141 - PUBLIC BUILDING/FACILITIES IMPACT FEES	25,538.17
303 - CDBG PROGRAM FUND	16,260.83
305 - CALTRANS GRANTS FUND	38,754.26
306 - SPECIAL REVENUE GRANTS FUND	5,730.34
501 - WATER ENTERPRISE FUND	346,760.22
502 - GAS ENTERPRISE FUND	156,876.08
503 - SEWER ENTERPRISE FUND	50,038.33
504 - SANITATION ENTERPRISE FUND	15,086.41
815 - LOW/MOD HOUSING ASSET FUND	331.00
820 - RORF-REDEV OBLIG RETIREMENT FUND (RDA)	1,308.21
950 - PAYROLL TRUST & AGENCY FUND	235,430.66
Grand Total:	1,403,313.98

Account Summary

Account Number	Account Name	Payment Amount
101-401-70010	Office Supplies	127.66
101-401-72030	Telephone	269.51
101-401-84010	Office Equip. Repairs &	23.26
101-401-88010	City Attorney Fees	34,804.78
101-401-88100	Professional Services	4,209.51
101-401-88220	Special Events Expense	380.00
101-404-70100	Uniforms	52.24
101-404-70160	Gasoline & Diesel	91.09
101-404-72030	Telephone	111.12
101-404-77440	CZE ABATEMENT REIMB	1,826.17
101-404-84010	Office Equip. Repairs &	23.82
101-404-86030	Subs., Dues, & Publicatio	8,237.00
101-404-86500	Planning-Reimbursable F	1,493.65
101-404-88101	Administrative Fees	0.46
101-404-98025	Outdoor Food Court	370.00
101-405-72030	Telephone	155.70
101-405-84010	Office Equip. Repairs &	43.34
101-405-86030	Subs., Dues, & Publicatio	205.93
101-405-88100	Professional Services	37.71
101-405-88101	Administrative Fees	13.99
101-406-72030	Telephone	12.09
101-406-82040	Office Equipment Rental	37.72
101-406-84010	Office Equip. Repairs &	9.60
101-406-88010	City Attorney Fees	1,090.31
101-406-88030	Accounting/Auditing	3,742.72
101-406-88100	Professional Services	1,033.73
101-408-60010	Salaries Regular	2,148.62
101-408-72030	Telephone	23.36
101-408-84010	Office Equip. Repairs &	118.47
101-408-88100	Professional Services	21.49
101-408-88101	Administrative Fees	3.76
101-408-89080	Background Investigatio	480.00

Account Summary

Account Number	Account Name	Payment Amount
101-413-70010	Office Supplies	321.50
101-413-70101	Uniforms-Safety Equipm	6,410.01
101-413-70160	Gasoline & Diesel	9,631.26
101-413-70380	Inmate Food/Jail Supplie	1,623.42
101-413-70440	Miscellaneous Supplies	180.17
101-413-72010	Water, Gas, Sanitation &	62.30
101-413-72020	Electric	23.45
101-413-72030	Telephone	4,579.30
101-413-84010	Office Equip. Repairs &	267.30
101-413-84060	Vehicle Parts, Repairs &	7,982.00
101-413-86010	Training, Travel, & Confe	2,846.93
101-413-86030	Subs., Dues, & Publicatio	757.10
101-413-88040	Computer Programming	1,980.45
101-413-88080	Laboratory	386.00
101-413-88100	Professional Services	1,991.28
101-413-88101	Administrative Fees	19.80
101-413-92211	K9 Program Expense	45.00
101-413-98040	Major Machinery & Equi	110,181.42
101-415-70440	Miscellaneous Supplies	93.95
101-415-72010	Water, Gas, Sanitation &	112.09
101-415-72030	Telephone	45.81
101-415-88100	Professional Services	3,472.00
101-415-98020	Buildings & Bldg. Improv	12,381.35
101-416-70010	Office Supplies	15.68
101-416-70040	Printing & Binding	114.54
101-416-70050	Education Materials & S	3,297.00
101-416-70102	Uniforms	1,541.09
101-416-70160	Gasoline & Diesel	11,838.02
101-416-70440	Miscellaneous Supplies	134.73
101-416-70450	Station Supplies	190.65
101-416-72010	Water, Gas, Sanitation &	2,024.92
101-416-72020	Electric	2,355.09
101-416-72030	Telephone	1,632.78
101-416-75030	Tuition Reimbursement	4,802.67
101-416-75060	Mandated Annual Servic	56,267.83
101-416-84010	Office Equip. Repairs &	140.61
101-416-84030	Buildings Repairs & Mai	3,824.46
101-416-84050	Grounds Repairs & Main	125.29
101-416-84060	Vehicle Parts, Repairs &	432.98
101-416-84070	Misc. Repairs & Maint.	472.90
101-416-86010	Training, Travel, & Confe	2,185.89
101-416-88040	Computer Programming	285.08
101-416-96057	CALPOP ENERGY EFF.LO	629.64
101-416-98040	Major Machinery & Equi	2,660.95
101-431-70060	Small Tools & Equipment	294.67
101-431-70100	Uniforms	181.48
101-431-70150	Vehicle Parts & Supplies	223.47
101-431-70160	Gasoline & Diesel	67.58
101-431-72030	Telephone	43.91
101-431-84060	Vehicle Parts, Repairs &	92.88
101-431-92090	Taxes, Licenses, & Fees	133.00
101-432-72010	Water, Gas, Sanitation &	3,192.35
101-432-72020	Electric	7,323.41
101-432-84030	Buildings Repairs & Mai	17,845.35
101-432-84071	Inspections	128.00
101-432-96057	CALPOP ENERGY EFF.LO	1,188.22
101-435-48163	Airshow Revenue	4.72
101-435-72010	Water, Gas, Sanitation &	613.09

Account Summary

Account Number	Account Name	Payment Amount
101-435-72020	Electric	917.87
101-435-72030	Telephone	19.84
101-435-84030	Buildings Repairs & Mai	696.46
101-435-84050	Grounds Repairs & Main	338.86
101-435-88100	Professional Services	260.00
101-435-88101	Administrative Fees	1.98
101-440-62080	Uniform Allowance	200.00
101-440-70060	Small Tools & Equipment	57.93
101-440-70100	Uniforms	343.04
101-440-70160	Gasoline & Diesel	1,510.17
101-440-72011	Water/Electric - City Plot	7,143.03
101-440-84050	Grounds Repairs & Main	2,166.91
101-440-84060	Vehicle Parts, Repairs &	546.77
101-440-84077	Landscaping & Lighting	1,306.01
101-440-88100	Professional Services	59.25
101-440-98981	Splash Pad Project	31,537.50
105-413-98041	COPS Grant Equipment E	18,078.27
106-413-98040	Major Machinery & Equi	26,437.88
107-422-60010	Salaries Regular	75.39
107-422-70100	Uniforms	211.24
107-422-70130	Street Materials	352.90
107-422-70160	Gasoline & Diesel	303.69
107-422-72011	Water/Electric - City Plot	3,652.53
107-422-72030	Telephone	9.80
107-422-84010	Office Equip. Repairs &	4.03
107-422-84050	Grounds Repairs & Main	87.18
107-422-84060	Vehicle Parts, Repairs &	861.02
107-422-88030	Accounting/Auditing	1,100.80
107-422-88100	Professional Services	2,797.33
107-422-88101	Administrative Fees	2.71
107-422-88130	Grant Writing/Applicatio	800.00
110-424-72021	Street Light Electricity	11,758.76
111-422-98911	Sacramento St Rehab	695.00
117-416-60010	Salaries Regular	490.04
117-416-70050	Education Materials & S	525.00
117-416-72030	Telephone	5.50
117-416-75000	Medical Equipment & Su	13,304.26
117-416-75010	Meals-Ambulance Runs	144.93
117-416-75040	Ambulance Billing Contr	12,116.22
117-416-75060	Mandated Annual Servic	7,114.80
117-416-84010	Office Equip. Repairs &	24.15
117-416-84060	Vehicle Parts, Repairs &	2,536.21
117-416-86040	Required Certification Tr	467.00
117-416-88100	Professional Services	4.90
117-416-88101	Administrative Fees	0.93
117-416-89080	BACKGROUND INVESTIG	320.00
125-422-98401	Slurry Seal & Cape Seal	947.50
126-422-98500	ADA Compliance/Plan Se	4,220.00
127-422-98976	Street Tree Maintenance	1,746.25
141-422-98985	Council Chambers Mode	25,538.17
303-405-88118	2022 CDBG Grant for FT	16,260.83
305-000-10003	Retention Payable	31,485.51
305-422-98062	STBG-California-Baker ST	3,015.00
305-422-98902	Phelps Ave Ph 2 Exp STP	1,161.25
305-422-98905	Los Gatos Bridge Trails-A	280.00
305-422-98926	CMAQ Trails Seg 6 5146	990.00
305-422-98965	Carbon Reduction Prog T	1,822.50
306-422-88106	Permanent Local Housin	187.18

Account Summary

Account Number	Account Name	Payment Amount
306-422-98850	Cal-Fire Tree Grant Expe	3,043.16
306-426-98580	Beverage Container Recy	2,500.00
501-000-10003	Retention Payable	-4,631.61
501-406-60010	Salaries Regular	75.39
501-406-70030	Postage & Freight Out	1,662.16
501-406-70040	Printing & Binding	598.53
501-406-70160	Gasoline & Diesel	62.69
501-406-72030	Telephone	113.75
501-406-84010	Office Equip. Repairs &	136.02
501-406-86010	Training, Travel, & Confe	67.50
501-406-88030	Accounting/Auditing	6,384.64
501-406-88100	Professional Services	635.09
501-406-88101	Administrative Fees	0.29
501-503-60010	Salaries Regular	226.17
501-503-70100	Uniforms	235.56
501-503-70140	Utility Parts & Supplies	378.25
501-503-70160	Gasoline & Diesel	3,043.42
501-503-70202	Lab Supplies	4,727.73
501-503-70210	Chemicals Ammonia	5,325.36
501-503-70230	Chemicals Chlorine	6,592.21
501-503-70240	Chemicals Aluminate Sul	8,075.97
501-503-70400	Chemicals Sodium Perm	19,104.05
501-503-72020	Electric	51,975.19
501-503-72030	Telephone	1,273.85
501-503-80010	Water Purchases	51,004.74
501-503-82030	Equipment Rental	40.00
501-503-84010	Office Equip. Repairs &	43.56
501-503-84020	Major Equip. Repairs &	48,992.88
501-503-84030	Buildings Repairs & Mai	5,025.00
501-503-84051	Grounds Chemicals & M	405.49
501-503-84072	Safety Equip. Repairs &	54.98
501-503-88010	City Attorney Fees	255.00
501-503-88081	Outside Laboratory	5,204.75
501-503-88100	Professional Services	5,736.20
501-503-88101	Administrative Fees	15.97
501-503-98030	Office Furniture & Equip	501.24
501-503-98040	Major Machinery & Equi	1,324.74
501-503-98441	Water Revenue Bond Pr	93,323.78
501-503-98471	CDWR Turf Replacement	3,103.00
501-508-60010	Salaries Regular	188.48
501-508-70060	Small Tools & Equipment	972.53
501-508-70100	Uniforms	304.60
501-508-70101	Uniforms-Safety Equipm	5,070.43
501-508-70140	Utility Parts & Supplies	2,925.68
501-508-70160	Gasoline & Diesel	2,830.42
501-508-72020	Electric	378.89
501-508-72030	Telephone	132.46
501-508-84010	Office Equip. Repairs &	21.10
501-508-84030	Buildings Repairs & Mai	260.79
501-508-84060	Vehicle Parts, Repairs &	82.85
501-508-86010	Training, Travel, & Confe	681.03
501-508-86030	Subs., Dues, & Publicatio	1,065.00
501-508-88100	Professional Services	4,695.70
501-508-88101	Administrative Fees	2.93
501-508-88130	Grant Writing/Applicatio	958.34
501-508-98040	Major Machinery & Equi	1,767.82
501-508-98054	Water Meters	2,398.13
501-508-98472	CDWR Advanced Meteri	929.50

Account Summary

Account Number	Account Name	Payment Amount
502-406-60010	Salaries Regular	75.39
502-406-70030	Postage & Freight Out	1,454.39
502-406-70040	Printing & Binding	524.12
502-406-70160	Gasoline & Diesel	54.86
502-406-72030	Telephone	99.27
502-406-84010	Office Equip. Repairs &	120.02
502-406-86010	Training, Travel, & Confe	56.25
502-406-88030	Accounting/Auditing	5,504.00
502-406-88100	Professional Services	71.23
502-406-88101	Administrative Fees	0.25
502-510-60010	Salaries Regular	188.48
502-510-70030	Postage & Freight Out	25.25
502-510-70100	Uniforms	304.60
502-510-70101	Uniforms-Safety Equipm	5,070.42
502-510-70140	Utility Parts & Supplies	1,057.33
502-510-70160	Gasoline & Diesel	2,830.40
502-510-70440	Miscellaneous Supplies	42.42
502-510-72020	Electric	1,106.39
502-510-72030	Telephone	441.59
502-510-80020	PG&E Wholesale Transp	129,112.68
502-510-80100	Gas Assistance Program	1,545.40
502-510-84010	Office Equip. Repairs &	36.93
502-510-84030	Buildings Repairs & Mai	219.32
502-510-84060	Vehicle Parts, Repairs &	77.11
502-510-88010	City Attorney Fees	80.67
502-510-88100	Professional Services	1,910.95
502-510-88101	Administrative Fees	5.21
502-510-88130	Grant Writing/Applicatio	958.33
502-510-98040	Major Machinery & Equi	1,767.82
502-510-98061	Anode Bed Rectifier Repl	2,135.00
503-406-60010	Salaries Regular	56.55
503-406-70030	Postage & Freight Out	955.74
503-406-70040	Printing & Binding	344.56
503-406-70160	Gasoline & Diesel	36.05
503-406-72030	Telephone	59.54
503-406-84010	Office Equip. Repairs &	66.99
503-406-86010	Training, Travel, & Confe	42.75
503-406-88030	Accounting/Auditing	4,183.04
503-406-88100	Professional Services	611.41
503-406-88101	Administrative Fees	0.18
503-520-60010	Salaries Regular	113.09
503-520-62081	Safety Boot Allowance	200.00
503-520-70010	Office Supplies	206.15
503-520-70100	Uniforms	109.44
503-520-70140	Utility Parts & Supplies	1,403.56
503-520-70160	Gasoline & Diesel	760.86
503-520-72010	Water, Gas, Sanitation &	930.04
503-520-72020	Electric	15,686.62
503-520-72030	Telephone	79.31
503-520-82030	Equipment Rental	20.00
503-520-84010	Office Equip. Repairs &	51.42
503-520-84020	Major Equip. Repairs &	1,330.18
503-520-84030	Buildings Repairs & Mai	30.00
503-520-84051	Grounds Chemicals & M	292.30
503-520-84060	Vehicle Parts, Repairs &	30.00
503-520-84073	Safety Equipment	54.98
503-520-88080	Laboratory	630.00
503-520-88100	Professional Services	751.13

Account Summary

Account Number	Account Name	Payment Amount
503-520-88101	Administrative Fees	5.08
503-521-60010	Salaries Regular	56.55
503-521-70100	Uniforms	211.24
503-521-70101	Uniforms-Safety Equipm	5,557.14
503-521-70140	Utility Parts & Supplies	2,844.22
503-521-70160	Gasoline & Diesel	2,437.14
503-521-70440	Miscellaneous Supplies	349.08
503-521-72010	Water, Gas, Sanitation &	111.03
503-521-72020	Electric	1,018.27
503-521-72030	Telephone	126.85
503-521-84010	Office Equip. Repairs &	9.02
503-521-84020	Major Equip. Repairs &	2,156.40
503-521-84030	Buildings Repairs & Mai	1,608.31
503-521-84060	Vehicle Parts, Repairs &	82.82
503-521-88010	City Attorney Fees	949.67
503-521-88100	Professional Services	750.57
503-521-88101	Administrative Fees	2.90
503-521-88130	Grant Writing/Applicatio	958.33
503-521-98040	Major Machinery & Equi	1,767.82
504-406-70030	Postage & Freight Out	83.11
504-406-70040	Printing & Binding	29.13
504-406-70160	Gasoline & Diesel	3.13
504-406-72030	Telephone	5.58
504-406-84010	Office Equip. Repairs &	7.41
504-406-86010	Training, Travel, & Confe	2.25
504-406-88030	Accounting/Auditing	220.16
504-406-88101	Administrative Fees	0.04
504-535-60010	Salaries Regular	37.70
504-535-70160	Gasoline & Diesel	856.00
504-535-88100	Professional Services	13,841.76
504-535-88101	Administrative Fees	0.14
815-609-88100	Professional Services	331.00
820-610-60010	Salaries Regular	37.65
820-610-72030	Telephone	2.45
820-610-84010	Office Equip. Repairs &	2.01
820-610-86010	Training, Travel, & Confe	11.25
820-610-88030	Accounting/Auditing	880.64
820-610-88100	Professional Services	236.63
820-610-88101	Administrative Fees	2.58
820-610-96512	Continuing Disclosure Fe	135.00
950-000-31100	Federal Withholding	53,406.71
950-000-31200	State Income Tax Withh	21,716.32
950-000-31300	FICA Withheld	89,475.88
950-000-31400	Medicare Insurance Wit	20,925.72
950-000-31500	State Disability Insuranc	9,521.45
950-000-32100	Employee Deferred Com	29,114.62
950-000-32400	Life Insurance	1,318.54
950-000-33000	CLOCEA Dues Withheld	1,104.82
950-000-33200	CPOA Dues Withheld	1,012.32
950-000-33300	Fire Assoc. Dues Withhel	650.00
950-000-34010	Other Withholdings Gar	1,614.66
950-000-34050	Garnishment Service Fe	375.81
950-000-34060	Prepaid Legal Services	152.81
950-000-34500	Unreimbursed Med/Dep	1,200.50
950-000-34600	AFLAC Insurance Withhe	3,840.50
	Grand Total:	1,403,313.98

Project Account Summary

Project Account Key
None

Payment Amount
1,403,313.98
1,403,313.98

Grand Total:

**STAFF REPORT - CITY COUNCIL/SUCCESSOR AGENCY/PUBLIC FINANCE
AUTHORITY**

Subject: Authorization for the City Manager to Enter into an Agreement with RAD Studios for On-Call Photography Services
Meeting Date: Thursday, April 2, 2026
From: Sean Brewer, City Manager
Prepared by: Sean Brewer, City Manager

I. RECOMMENDATION:

Staff recommends that the City Council:

- Authorize the City Manager to enter into a City Standard Professional Services Agreement with RAD Studios to provide on-call photography services for the City of Coalinga; and
- Authorize the City Manager to execute all related documents necessary to implement the agreement.

II. BACKGROUND:

The City of Coalinga regularly utilizes photography services to support community engagement, public information efforts, economic development initiatives, and documentation of municipal activities. Photography assets are used across multiple platforms including the City website, social media, press releases, printed materials, grant applications, and archival documentation.

To ensure the City has access to professional, high-quality photography when needed, staff issued a Request for Qualifications (RFQ) for On-Call Photography Services. The RFQ sought qualified photographers capable of providing services on an as-needed basis to document City events, facilities, infrastructure projects, community activities, and official City functions.

The intent of the RFQ was to identify a qualified photographer who could provide responsive, professional photography services that support the City's communications, documentation, and outreach needs.

III. DISCUSSION:

The City received two proposals in response to the RFQ:

- RAD Studios
- Narrative Form LLC

Staff reviewed both proposals based on the evaluation criteria identified in the RFQ, including:

- Relevant experience and qualifications
- Quality of work samples and portfolio
- Availability and responsiveness
- Proposed fee structure

- Overall best value to the City

RAD Studios submitted a proposal offering an hourly rate of \$150 per hour, which includes equipment, setup, travel time, and editing services. Narrative Form LLC offered a rate of \$250 per hour.

RAD Studios is a locally owned business with experience providing photography, videography, and aerial drone services. The firm holds an FAA Part 107 drone license and has completed a variety of projects including headshots, event photography, promotional materials, and aerial photography for local schools and businesses.

Staff determined that RAD Studios provides a competitive fee structure, demonstrated familiarity with the Coalinga community, and has the ability to respond quickly to City needs for event coverage, project documentation, and promotional imagery.

While Narrative Form LLC demonstrated significant professional experience working with national tourism organizations and global brands, their proposed hourly rate of \$250 per hour and higher project-based rates were substantially higher than the proposal submitted by RAD Studios.

Based on the evaluation of proposals, staff recommends selecting RAD Studios as the City's on-call photography provider due to its cost effectiveness, local familiarity, and ability to provide responsive services to support the City's needs.

IV. ALTERNATIVES:

- • Approve the recommendation and authorize the City Manager to execute the agreement with RAD Studios.
- Direct staff to negotiate with another proposer.
- Reject all proposals and direct staff to reissue the RFQ.

-

V. FISCAL IMPACT:

Photography services will be provided on an as-needed basis and billed hourly in accordance with the agreement. Costs will be funded through existing departmental budgets when photography services are requested.

ATTACHMENTS:

File Name	Description
<input type="checkbox"/> Agreement_-_On-Call_Photography_Services_-_RAD_Studios.pdf	Agreement - On-Call Photography Services - RAD Studios

AGREEMENT FOR PROFESSIONAL SERVICES FOR ON-CALL PHOTOGRAPHY SERVICES

This Agreement for Professional Services (“Agreement”) is made and entered into this _____ day of April by and between the City of Coalinga, a Municipal Corporation (“City”), and RAD Studios (“Provider”).

RECITALS

- A. Provider represents to City that they are specially trained, experienced, licensed and competent to perform the services which will be required by this Agreement; and
- B. Provider represents to City that they possess the skill, experience, ability, background, certification and knowledge to provide the services described in this Agreement on the terms and conditions described herein.
- C. City desires to retain Provider to render the services as set forth in this Agreement, as Exhibit 1.

NOW THEREFORE, in consideration of the mutual covenants set forth herein for such other good and valuable consideration, the receipt and adequacy of which is hereby acknowledged, the parties hereto agree as follows:

1. **Retention of Provider.** Subject to the terms and conditions set forth herein, City retains Provider to perform the services identified in this Agreement, as an independent contractor and Provider hereby accepts this independent contractor appointment.
2. **Scope of Services.** The Provider shall perform professional services, in accordance with all the provisions of this Agreement. The Scope of Work is attached hereto as Exhibit 1. Provider shall correct any and all errors and/or omissions, which arise out of Provider’s negligence or intentional misconduct, in the performance of the Services and any documents resulting therefrom even though City has accepted said Services or documents. Provider shall make such corrections upon City’s request and at no cost or expense to City.
3. **Time of Performance.** This agreement shall remain in effect until canceled by either party. Contract time of completion for individual projects will be agreed upon before assignment of each project to Provider. Services designated in the scope of work shall be completed on agreed date unless prior written approval for a time extension has been granted by the City Manager or his/her designee.
4. **Compensation.** Compensation to be paid to Provider at the rate of \$150.00 per hour which includes setup, travel time on scene time and editing.
5. **Method of Payment.** Provider shall submit monthly billings to City describing the work performed during the preceding month. Provider’s bills shall include a brief description of the Services performed and the date the Services were performed the number of hours spent and by whom, and a description of any reimbursable expenditures. City shall pay Provider no later than 30

days after the date of submittal of a complete invoice for completed tasks and approval of the invoice by City staff.

6. **Extra Work.** At any time during the term of this Agreement, City may request that Provider perform Extra Work. As used herein, “Extra Work” means any work which is determined by City to be necessary for the proper completion of the Services, but which the parties did not include in the Scope of Work. Extra work will be performed on an hourly basis under the Provider’s most current hourly fee schedule. Provider shall not perform, nor be compensated for Extra Work without written authorization from City.

7. **Termination.** This Agreement may be terminated by the City immediately and without notice for cause or by City without cause upon ten (10) days’ written notice of termination to Provider. Upon termination, Provider shall be entitled to compensation for Services performed up to the effective date of termination, unless this Agreement is terminated for cause, in which case, City may withhold compensation due Provider in order to reimburse City for any losses, damages or expenses caused by Provider’s default under this Agreement.

8. **Equal Opportunity Employment.** Provider represents that it is an equal opportunity employer and it shall not discriminate against any sub provider, employee or applicant for employment because of race, religion, color, national origin, handicap, ancestry, sex or age. Such non-discrimination shall include, but not be limited to, all activities related to initial employment, upgrading, demotion, transfer, recruitment or recruitment advertising, layoff or termination. Provider shall also comply with all relevant provisions of City’s programs or guidelines currently in effect as identified and provided to Provider by City.

9. **Insurance Requirements.**

a. Provider, at Provider’s own cost and expense, shall procure and maintain, for the duration of this Agreement, the following insurance policies.

i. **Workers Compensation Coverage.** As required by the State of California, with Statutory Limits, and Employer’s Liability Insurance with a limit of no less than ONE MILLION AND NO/100 DOLLARS (\$1,000,000) per accident for bodily injury or disease.

ii. **General Liability Coverage.** Insurance Services Office (ISO) Form CG 0001, including products and completed operations, with limits of no less than ONE MILLION AND NO/100 DOLLARS (\$1,000,000) per occurrence for bodily injury, personal injury, and property damage. If a general aggregate limit applies, either the general aggregate limit shall apply separately to this project/location or the general aggregate limit shall be TWO MILLION AND NO/100 DOLLARS (\$2,000,000), twice the required occurrence limit.

iii. **Automobile Liability Coverage.** ISO Form Number CA 0001 covering any auto (Code 1), with a limit no less than ONE MILLION AND NO/100 DOLLARS (\$1,000,000) per accident for bodily injury and property damage.

iv. **Professional Liability Coverage.** Contractor will maintain Professional Liability coverage with limits no less than ONE MILLION AND NO/100 DOLLARS

(\$1,000,000) per occurrence or claim, and TWO MILLION AND NO/100 DOLLARS (\$2,000,000) policy aggregate.

If Provider maintains higher limits than the minimums shown above, the City requires and shall be entitled to coverage for the higher limits maintained by Provider.

Provider's insurance policies shall be "occurrence" policies and not "claims-made" coverage except for Professional Liability Coverage.

Provider may maintain an Umbrella policy in conjunction with the insurance policies referenced above. In such case, Provider shall be deemed to have satisfied the insurance requirements of this contract as long as: (i) the coverage limits of the Umbrella policy and of the underlying liability policy(ies), when combined, satisfy each of the per occurrence and aggregate requirements identified in this subsection a.; and (ii) coverage under the Umbrella policy is as broad as and includes all incidents and events covered by the underlying insurance that it supplements.

Any deductibles or self-insured retentions must be declared to and approved by the City. The City may require Provider to purchase coverage with a lower deductible or retention or provide proof of ability to pay losses and related investigations, claim administration, and defense expenses within the retention. Alternatively, the City may require Provider to provide a financial guarantee satisfactory to the City guaranteeing payment of losses and related investigations, claim administration, and defense expenses within the retention.

The policies are to contain, or be endorsed to contain, the following provisions:

i. The City and its officers, officials, employees, and volunteers are to be covered as additional insureds on the CGL and automobile liability policies with respect to liability arising out of work or operations performed by or on behalf of Provider including materials, parts, or equipment furnished in connection with such work or operations; products used by Provider; or automobiles owned, leased, hired or borrowed by Provider. General liability coverage can be provided in the form of an endorsement to Provider's insurance at least as broad as ISO Form CG 20 10 11 85 or if not available, through the addition of both CG 20 10 and CG 20 37 if a later edition is used. The coverage shall contain no special limitations on the scope of protection afforded to the City, its officers, officials, employees or volunteers.

ii. For any claims related to this contract, Provider's insurance coverage shall be primary insurance as respects the City and its officers, officials, employees, and volunteers. Any insurance or self-insurance maintained by the City and/or its officers, officials, employees, or volunteers shall be in excess of Provider's insurance and shall be non-contributory.

iii. Each insurance policy required above shall provide that coverage shall not be canceled, except with notice to the City.

Insurance is to be placed with insurers with a current A.M. Best's rating of no less than A:VII.

Provider shall furnish the City with original certificates and amendatory endorsements or copies of the applicable policy language effecting coverage required by this clause. All certificates and endorsements are to be received and approved by the City before work commences. However, failure to obtain the required documents prior to the work beginning shall not waive the Provider's obligation to provide them. The City reserves the right to require complete, certified copies of all required insurance policies, including endorsements required by these specifications, at any time.

Provider hereby grants to City and its officers, officials, employees, and volunteers a waiver of any right to subrogation which any insurer of Provider may acquire against the City and/or its officers, officials, employees, and volunteers by virtue of the payment of any loss under such insurance. Provider agrees to obtain endorsements necessary to effect this waiver of subrogation, but this provision applies regardless of whether or not the City has received a waiver of subrogation endorsement from the insurer.

The City reserves the right to modify the insurance requirements contained in this contract, including, without limitation, coverage limits, based on the nature of the risk, prior experience, insurer, coverage, or other special circumstances.

10. **Indemnification.** To the fullest extent allowable by law, Provider agrees to indemnify, defend and hold harmless the City and its officials, officers, employees, agents and volunteers from and against all claims, demands, actions, injuries, liabilities, losses, costs or damages, direct or indirect, and any and all attorneys' fees and other expenses which City or its officials, officers, employees, agents or volunteers may sustain or incur as a consequence of or are in any way related to Provider's or its owners, directors, officers, managers, employees, agents and subcontractor's willful or negligent acts or omissions in the performance of the services and Providers responsibilities and obligations to be performed under this agreement or its failure to perform or comply with any of its obligations or responsibilities contained in this agreement; excluding, however, such liability, claims, losses, damages or expenses arising from City's sole or active negligence or willful acts. This duty to indemnify, defend, and hold harmless shall survive the termination of this agreement. If Provider maintains additional coverage or higher limits than those required herein, then City shall be entitled to additional coverage or higher limits maintained by Provider.

11. **Independent Contractor Status.** It is understood and agreed that Provider, in the performance of the Services to be performed pursuant to this Agreement, shall act as and be an independent contractor and shall not act as an agent or employee of City. Provider shall obtain no retirement benefits or other benefits which accrue to City's employees and Provider hereby expressly waives any claim it may have to any such rights. Nothing in this Agreement shall create or be construed as creating a partnership, joint venture or any other relationship between City and Provider.

12. **Provider's Books and Records.**
a. Provider shall maintain any and all ledgers, books of account, invoices, vouchers, canceled checks, and other records or documents evidencing or relating to charges for services, or expenditures and disbursements charged to City for a minimum period of three (3) years, or for any longer period required by law, from the date of final payment to Provider under this Agreement.

b. Provider shall maintain all documents and records that demonstrate performance under this Agreement for a minimum period of three (3) years, or for any longer period required by law, from the date of termination or completion of this Agreement.

c. Any records or documents required to be maintained pursuant to this Agreement shall be made available for inspection or audit, at any time during regular business hours, upon written request by the City. Copies of such documents shall be provided to the City for inspection at the City offices.

d. Where City has reason to believe that such records or documents may be lost or discarded due to dissolution, disbandment or termination of Provider's business, City may, by written request, require that custody of the records be given to the City and that the records and documents be maintained in the City offices. Access to such records and documents shall be granted to any party authorized by Provider, Provider's representatives, or Provider's successor-in-interest.

13. **Professional Ability of Provider.** City has relied upon Provider's representations regarding its training and professional ability to perform the Services hereunder as a material inducement to enter into this Agreement. Provider shall therefore provide properly skilled personnel to perform all Services under this Agreement. The primary provider of the Services called for by this Agreement shall be [NAME] who shall not be replaced without the written consent of the City. All work performed by Provider under this Agreement shall be in accordance with the applicable professional standard of care and shall meet the local professional standard of quality ordinarily to be expected of competent persons in Provider's field of expertise working in Fresno County.

14. **Compliance with Laws.** Provider shall use the proper standard of care in performing the Services and shall comply with all applicable federal, state and local laws, codes, ordinances and regulations in effect at the time the Agreement is executed. In addition, if the request for proposal to provide professional services which are the subject of this Agreement cited any federal or state financial assistance involved in the project for which the Services are provided, the Provider shall perform all services in accordance with all applicable federal and state laws, rates and regulations in effect at the time the agreement is executed.

15. **Licenses.** Provider represents and warrants to City that it has all licenses, permits, qualifications, and insurance which are legally required of Provider to lawfully and competently perform the Services. Provider represents and warrants to City that Provider shall, at its sole cost and expense, keep in effect or obtain at all times during the term of this Agreement, any licenses, permits, and insurance which are legally required of Provider to lawfully and competently perform the Services. Provider shall maintain a City of Coalinga business license.

16. **Assignment and Subcontracting.** The parties recognize that a substantial inducement to City for entering into this Agreement is the reputation, experience and competence of Provider. Assignments of any or all rights, duties or obligations of the Provider under this Agreement will be permitted only with the express written consent of the City, which will not be unreasonably withheld. Provider shall not subcontract any portion of the Services to be performed under this Agreement without the express written consent of the City, which will not be unreasonably withheld. If City consents to such subcontract, Provider shall be fully responsible to City for all acts or omissions of the subcontractor. Nothing in this Agreement shall: (1) create any contractual relationship between

City and sub Provider; (ii) create any obligation on the part of the City to pay or to see to the payment of any monies due to any such subcontractor; (iii) or relieve Provider of any of its obligations and responsibilities under this Agreement.

17. **Attorneys' Fees.** If an action at law or in equity is necessary to enforce or interpret the terms of this Agreement, the prevailing party shall be entitled to reasonable attorneys' fees, costs and necessary disbursements in addition to any other reasonable relief to which he may be entitled. With respect to any suit, action or proceeding arising out of or related to this Agreement, or the documentation related hereto, the parties hereby submit to the jurisdiction and venue of the Superior Court for the County of Fresno, State of California for any proceeding arising hereunder.

18. **Sole and Only Agreement.** This Agreement supersedes any and all other agreements, either oral or in writing, between the parties hereto with respect to the matters set forth herein and contains all of the covenants and agreements between the parties regarding said matters. Each party to this Agreement acknowledges that no representations, inducements, promises or agreements, orally or in writing, have been made by any party or anyone acting on behalf of any party which are not embodied in this Agreement and no other agreement, statement or promise shall be valid or binding.

19. **Invalidity.** If any provision of this Agreement is held by a court of competent jurisdiction to be invalid, void or unenforceable, the remaining provisions shall nevertheless continue in full force and effect without being impaired or invalidated in any way.

20. **Amendment.** No change, amendment or modification of this Agreement shall be valid unless the same be in writing and signed by the parties hereto.

21. **Governing Law.** This Agreement shall be construed and governed pursuant to the laws of the State of California. Any action to enforce this Agreement is to be brought in Fresno County, California.

22. **Waiver.** Waiver of a breach or default under this Agreement shall not constitute a continuing waiver of a subsequent breach of the same or any other provision under this Agreement.

23. **Mediation.** The parties agree to make a good faith attempt to resolve any disputes arising out of this Agreement through mediation prior to commencing litigation. The parties shall mutually agree upon the mediator and shall divide the costs of mediation equally. If the parties are unable to agree upon a mediator, the dispute shall be submitted to JAMS/ENDISPUTE ("JAMS") or its successor in interest. JAMS shall provide the parties with the names of five qualified mediators. Each party shall have the option to strike two of the five mediators selected by JAMS and thereafter the mediator remaining shall hear the dispute. If the dispute remains unresolved after mediation, either party may commence litigation.

24. **Authority to Enter Agreement.** Provider has all requisite power and authority to conduct its business and to execute, deliver and perform the Agreement. Each party warrants that the individuals who have signed this Agreement have the legal power, right, and authority to make this Agreement and to bind each respective party.

25. **Notice.** Except as otherwise expressly provided herein, any notice, consent, authorization or other communication to be given hereunder shall be in writing and shall be deemed duly given and received when delivered personally, when transmitted by facsimile or e-mail if receipt is acknowledged by the addressee, one business day after being deposited for next-day delivery with a nationally recognized overnight delivery service, or three business days after being mailed by first class mail, charges and postage prepaid, property addressed to the party to receive such notice at the last address furnished for such purpose by the party to whom notice is directed and addressed as follows:

CITY:

City of Coalinga
155 West Durian
Coalinga, California 93210

PROVIDER:

Ryan Arguello, RAD Studios
3047 Carmele Court
Coalinga, CA 93210

IN WITNESS WHEREOF, the parties have executed this Agreement effective on the day and in the year first set forth above.

CITY OF COALINGA, a Municipal Corporation

By: _____
Sean Brewer, City Manager

PROVIDER

By: _____
Ryan Arguello, Owner

APPROVED AS TO CONTENT:

ATTEST:

Mario Zamora
City Attorney

City Clerk
Shannon Jenson

Exhibit 1 Scope of Work

The Consultant shall provide professional photography services to the City on an on-call, as-needed basis. Services shall include, but are not limited to, capturing high-quality images of City events, operations, facilities, personnel, and programs for documentation, communication, and promotional purposes.

Photography services may include coverage of City-sponsored events; City Council meetings and official functions; public outreach and community engagement activities; municipal facilities, parks, and infrastructure projects (including pre-, during, and post-construction); public safety personnel, training, and community interactions (excluding confidential or tactical operations); and economic development, marketing, and branding initiatives.

Services shall also include professional portraits and group photographs of City Council, staff, and departments; as well as archival and documentation photography to support reporting, compliance, grant applications, and historical records.

**STAFF REPORT - CITY COUNCIL/SUCCESSOR AGENCY/PUBLIC FINANCE
AUTHORITY**

Subject: Introduce and Waive First Reading of Ordinance No. 878 Amending Chapter 6 of Title 7 of the Coalinga Municipal Code Relating to Summary Abatement of Public Nuisances

Meeting Date: Thursday, April 2, 2026

From: Sean Brewer, City Manager

Prepared by: Mario Zamora, City Attorney

I. RECOMMENDATION:

Introduce and Waive First Reading of Ordinance No. 878 an ordinance of the City of Coalinga, California, Amending Chapter 6 of Title 7 of the Coalinga Municipal Code Relating to Summary Abatement of Public Nuisances.

II. BACKGROUND:

Fire incidents within the City of Coalinga have raised questions about the City's authority to immediately abate and place liens on fire-damages or burned properties within the City limits. Under Chapter 6 of Title 7 of the Coalinga Municipal Code, the City has an established property maintenance and nuisance abatement process. This process requires: (a) notice to the property owner describing the nuisance and required corrective action; (b) an opportunity for the owner to request an abatement hearing before the City Manager and appeal to the City Council; (c) City-performed abatement if the nuisance is not corrected; and (d) Council approval of abatement costs prior to placement of a lien, special assessment, or personal obligation.

On February 5, 2026, the City Council reviewed a sample summary abatement ordinance from the City of Carlsbad, which outlined streamlined emergency authority, required documentation, post-abatement notice, and a path for confirmation of costs and lien placement.

III. DISCUSSION:

The attached ordinance provides for a summary abatement process. The abatement provides that a nuisance may be summarily abated without notice, hearing, or a warrant when immediate action is necessary to preserve or protect the public health and safety. The City Manager or designee shall make a determination that a public nuisance exists, posing an immediate risk to the health, safety, or welfare of the public, persons in the city, or the environment. The City Manager or designee shall attempt to contact the responsible party and property owner to request abatement of the nuisance prior to the City proceeding with summary abatement. Upon such notice, the City Manager board, fence, or secure the building or site, raze and grade that portion of the building or site to prevent collapse or remove any hazard to the general public, and take any other action as reasonably appropriate under the circumstances of an immediate hazard.

The City Manager or designee shall prepare a report of summary abatement that contains a description of the time, duration, type, and extent of the nuisance; an evaluation of the risks to the health, safety, and welfare caused by allowing the nuisance to continue; steps taken to contact the responsible party or property owner; and all costs associated with the summary abatement. Within ten (10) business days after the determination is

made by the City Manager or designee to summarily abate the nuisance, a notice of determination and a copy of the report of summary abatement shall be served on the responsible party, the owner of record of the parcel of land where the nuisance originated, and all persons known to have any legal interest in the property.

Subsequently, a hearing to assess abatement costs and affirm whether immediate action was necessary to preserve or protect the health, safety, and/or welfare of the public, persons in the city and/or the environment shall be conducted before the City Council at the request of the responsible party and/or the property owner. The City Council shall determine whether the nuisance posed an immediate risk to the health, safety, or welfare of the public, persons in the City, and/or the environment; whether the responsible party and/or property owner was unavailable, incapable, and/or unwilling to abate the nuisance; the correct abatement cost; and confirm the report of summary abatement as presented or modified, among other things. The decision of the City Council shall be final.

In addition to any other applicable procedures, the cost of summary abatement may be collected or become a lien or special assessment against the real property.

IV. ALTERNATIVES:

1. Revise the Summary Abatement Ordinance with additional provisions
2. Not approve the Summary Abatement Ordinance

V. FISCAL IMPACT:

Fiscal impact is realized at the time of nuisance determination and subsequent abatement activities. All associated costs incurred by the City are recoverable through direct billing, property liens, or special assessments. Accordingly, while there may be short-term cash flow impacts, the long-term fiscal effect to the City is minimal.

ATTACHMENTS:

File Name	Description
☐ Summary_Abatement_Ordinance_878.pdf	Summary Abatement Ordinance No. 878

ORDINANCE NO. 878

AN ORDINANCE OF THE CITY COUNCIL OF THE CITY OF COALINGA AMENDING CHAPTER 6 OF TITLE 7 OF THE COALINGA MUNICIPAL CODE RELATING TO SUMMARY ABATEMENT OF PUBLIC NUISANCES

The City Council of the City of Coalinga does hereby ordain as follows:

Section 1. Article 4 of Title 7 of the Coalinga Municipal Code is hereby amended to read as follows:

“Article 4. – Summary abatement”

Section 2. Section 7-6.401 of the Coalinga Municipal Code is hereby amended to read as follows:

Section 7-6.401 General.

A nuisance may be summarily abated without notice, hearing, or a warrant when immediate action is necessary to preserve or protect the public health and safety. Summary abatement actions are not subject to all of the requirements of Article 3 of this chapter, but instead shall be subject to the following requirements.

Section 3. Section 7-6.402 of the Coalinga Municipal Code is hereby amended to read as follows:

Section 7-6.402 Determination of summary abatement.

- A. The City Manager or designee shall make a determination that a public nuisance exists that poses an immediate risk to the health, safety, or welfare of the public, persons in the city, or the environment.
- B. Whenever possible, the city shall attempt to contact the responsible party and property owner to request abatement of the nuisance prior to the city proceeding with summary abatement. If the responsible party and property owner are not available, or are incapable, or unwilling to abate the nuisance, the city may proceed with summary abatement using the minimum level of correction or abatement as necessary to eliminate the immediacy of the hazard.
- C. Notwithstanding the requirement in subsection B, the City Manager or designee may exercise the following powers without prior notice to the responsible party and property owner:
 - 1. Order the immediate vacation of any tenants and prohibit occupancy until all repairs are completed.
 - 2. Post the premises as unsafe, substandard, or dangerous.
 - 3. Board, fence, or secure the building or site.

4. Raze and grade that portion of the building or site to prevent further collapse and remove any hazard to the general public.
5. Make any minimal emergency repairs as necessary to eliminate any imminent life safety hazard.
6. Take any other action as reasonably appropriate under the circumstances of an immediate hazard.
7. Exercise any of the summary abatement powers listed in this subsection to remove items placed or stored on city property, sidewalks, or public rights-of-way.
8. Pursue any administrative or judicial remedy to abate any remaining public nuisance.

Section 4. Section 7-6.403 of the Coalinga Municipal Code is hereby amended to read as follows:

Section 7-6.403 Summary abatement cost report.

- A. The City Manager or designee shall maintain the following records and shall prepare a report of summary abatement that contains the following:
 1. A description of the time, duration, type, and extent of the nuisance;
 2. An evaluation of the risks to the health, safety, and welfare of the public and/or the environment caused by allowing the nuisance to continue;
 3. Steps taken to contact the responsible party and property owner;
 4. All costs associated with the investigation and summary abatement of the nuisance, including the costs of personnel, equipment, facilities, materials, and other external resources.
- B. Within ten (10) business days after the determination is made by the City Manager or designee to summarily abate the nuisance, a notice of determination and a copy of the report of summary abatement shall be served on the responsible party, the owner of record of the parcel of land where the nuisance originated, and all persons known to have any legal interest in the property. The city may charge the responsible party or the property owner with the full costs of investigation and summary abatement of the nuisance.

Section 5. Section 7-6.404 of the Coalinga Municipal Code is hereby amended to read as follows:

Section 7-6.404 Summary abatement hearing.

- A. A hearing to assess abatement costs and affirm whether immediate action was necessary to preserve or protect the health, safety, and/or welfare of the public, persons in the city and/or the environment shall be conducted before

the City Council at the request of the responsible party and/or the property owner.

- B. The responsible party and/or the property owner must file a written request for a hearing with the City Clerk within thirty (30) calendar days of the receipt of the notice of determination and report of summary abatement.
- C. The hearing shall be scheduled before the City Council within sixty (60) calendar days of receipt of the request for a hearing.
- D. Within thirty (30) calendar days of receipt of the notice of determination and the report of summary abatement, and at least thirty (30) calendar days prior to the scheduled hearing date, the responsible party and/or property owner may file a request with the City Clerk for any and all evidence and objections regarding the need for summary abatement and/or the abatement costs.
- E. The hearing and consideration may be continued from time to time and upon its conclusion, the City Council shall, by resolution:
 - 1. Determine whether the nuisance posed an immediate risk to the health, safety, or welfare of the public, persons in the city, and/or the environment.
 - 2. Determine whether the responsible party was unavailable, incapable, and/or unwilling to abate the nuisance.
 - 3. Determine the correct abatement cost.
 - 4. If necessary, modify the report of summary abatement to conform such findings as indicated above.
 - 5. Confirm the report of summary abatement as presented or modified.
 - 6. State the date of the summary abatement order.
 - 7. Determine and state the correct legal description of the subject property, the correct county assessor's parcel number, the street address, and the name and address of the record owner based on the last equalized assessment roll or the supplemental roll, whichever is more current.
- F. The decision of the City Council shall be final.

Section 6.

Section 7-6.405 of the Coalinga Municipal Code is hereby amended to read as follows:

Section 7-6.405 Collection of cost of summary abatement.

In addition to any other applicable procedures, the cost of summary abatement may be collected in accordance with Section 7-6.304 or become a lien or special assessment against the property in accordance with Section 7-6.305.

Section 7. Article 5 of Title 7 of the Coalinga Municipal Code is hereby amended to read as follows:

“Article 5. – Penalties”

Section 8. Section 7-6.501 of the Coalinga Municipal Code is hereby amended to read as follows:

Section 7-6.501 Civil fines.

Any person who violates any of the provisions of this chapter or any of the provisions of any written authority issued by the Director of Public Works, or his designee, shall be liable for a civil penalty of not less than one hundred dollars (\$100.00), nor more than one thousand dollars (\$1,000.00), per day for each and every day, or any part thereof, during which any such violation is committed, continued or permitted, which shall be assessed and recovered in a civil action brought in the name of the City.

In any civil action commenced by the City under this chapter, the City shall be entitled to recover from the defendant in any such action reasonable attorney's fees and costs of suit.

Section 9. Section 7-6.502 is hereby added to Article 5 of Title 7 of the Coalinga Municipal Code to read as follows:

Section 7-6.502 Infraction/misdemeanor.

Any person who violates any of the provisions of this chapter or any of the provisions of any written authority issued by the Director of Public Works, or his designee, shall be guilty of an infraction/misdemeanor. Each and every day, or any part thereof, during which any such violation is committed, continued or permitted, shall be a separate offense.

Section 10. Section 7-6.503 is hereby added to Article 5 of Title 7 of the Coalinga Municipal Code to read as follows:

Section 7-6.503 Prosecution.

Every violation of this chapter shall be a misdemeanor; provided, however, that where the City Attorney has determined that such action would be in the best interests of justice, the City Attorney may specify in the accusatory pleading that the violation shall be prosecuted as an infraction.

Section 11. Section 7-6.504 is hereby added to Article 5 of Title 7 of the Coalinga Municipal Code to read as follows:

Section 7-6.504 Penalty for infraction.

Each and every violation of this chapter which is deemed an infraction is punishable by:

- (a) A fine not exceeding one hundred dollars (\$100.00) for the first violation;
- (b) A fine not exceeding two hundred dollars (\$200.00) for the second violation of the same or similar provision within a one-year period; or
- (c) A fine not exceeding five hundred dollars (\$500.00) for each additional violation, after the second, of the same or similar provision of this chapter within a one-year period of the first violation.

Section 12. Section 7-6.505 is hereby added to Article 5 of Title 7 of the Coalinga Municipal Code to read as follows:

Section 7-6.505 Penalty for misdemeanor.

Each and every violation of this chapter which is deemed a misdemeanor is punishable by a fine of not more than one thousand dollars (\$1,000.00), or by imprisonment in the City or County jail for a period of not exceeding six (6) months, or by both fine and imprisonment.

Section 13. Article 6 of Title 7 is hereby added to the Coalinga Municipal Code to read as follows:

“Article 6. – Severability”

Section 14. Section 7-6.601 is hereby added to Article 6 of Title 7 of the Coalinga Municipal Code to read as follows:

Section 7-6.601 Severability.

If any provision, clause, sentence or paragraph of this chapter or the application thereof to any person or circumstances shall be held invalid, such invalidity shall not affect the other provisions or applications of the provisions of this chapter which can be given effect without the invalid provision or application, and to this end, the provisions of this chapter are declared severable.

Section 15. This ordinance shall take effect thirty (30) days after its adoption.

Section 16. The City Clerk is authorized and directed to cause this ordinance or a summary of this ordinance to be published once in a newspaper of general circulation published and circulated in the City of Coalinga, within fifteen (15) days after its adoption. If a summary of this ordinance is to be published, then the City Clerk

shall cause a summary of the proposed ordinance to be published and a certified copy of the full text of the proposed ordinance to be posted in the office of the City Clerk at least five (5) days prior to the Council meeting at which the ordinance is adopted, and also shall cause a certified copy of the full text of the adopted ordinance to be posted in the office of the City Clerk after the meeting at which the ordinance is adopted. The summaries shall be approved by the City Attorney.

* * * *

The foregoing ordinance was introduced by the City Council of the City of Coalinga, California, at a regular meeting held on April 2, 2026, and was passed and adopted by the City Council on April 16, 2026, by the following vote:

AYES:

NOES:

ABSENT:

ABSTAIN:

APPROVED:

Mayor

ATTEST:

City Clerk/Deputy City Clerk

**STAFF REPORT - CITY COUNCIL/SUCCESSOR AGENCY/PUBLIC FINANCE
AUTHORITY**

Subject: Adopt Resolution No. 4314 Approving a Budget Adjustment for Fire Department LED Sign
Meeting Date: Thursday, April 2, 2026
From: Greg DuPuis, Fire Chief
Prepared by: Greg DuPuis, Fire Chief

I. RECOMMENDATION:

Adopt Resolution No. 4314 memorializing and confirming the City Council's March 19, 2026 approval of a budget adjustment for the installation of a programmable LED electronic message sign at the fire station. The original design was previously approved as a one-time project on June 18, 2025 in the amount of \$25,000. The revised project replaces the damaged sign with a larger monument-style LED sign and supports time-sensitive public safety information, emergency notifications, recruitment messaging, and community engagement updates.

II. BACKGROUND:

On March 19, 2026, the City Council approved a budget adjustment for the Fire Department LED sign project. The staff report presented at that meeting described the need for a larger programmable sign to replace the damaged existing sign and improve public communication.

The Fire Department currently relies on static signage, social media, and the City website to share information. While effective for some audiences, those platforms do not reach all residents, particularly those who do not use social media, do not frequently visit the City website, or require immediate visible location-based notifications. An LED message sign provides real-time, high-visibility communication to residents traveling through the area. The current signage is no longer illuminated, and the new illuminated lettering would be consistent with signage on other City properties such as City Hall and the Police Department.

III. DISCUSSION:

The LED sign is an enhanced public safety communication tool. The sign will be used to display:

- Emergency alerts (road closures, severe weather warnings, wildfire conditions)
- Disaster preparedness information
- Fire prevention messaging
- CPR/AED training announcements
- Smoke detector campaign reminders

The original sign project was developed prior to a vehicle accident on July 29, 2025, which resulted in damage to the existing sign. Following the accident, the scope of the project was revised to replace the damaged structure with a monument-style LED sign.

The updated design is larger and significantly enhances the Fire Department's ability to communicate information to the community.

After the March 19, 2026 action, staff identified that the associated resolution number had not been assigned. Adoption of this item formalizes the Council's prior action in resolution form without changing the project scope or the budget amount previously approved.

IV. ALTERNATIVES:

1. Do not adopt the resolution and leave the prior Council action without a numbered resolution in the record.

V. FISCAL IMPACT:

There is no new fiscal impact associated with this action. The updated estimate for the larger two-sided programmable LED display monument sign and replacement of current wall signage on the Elm Street side of the property remains approximately \$72,000, consisting of \$62,409.70 for the two-sided monument sign and illuminated signs, \$2,981.15 for the electrical connection, and a 10% contingency. The budget adjustment previously approved was approximately \$47,000.

ATTACHMENTS:

File Name	Description
📎 fire_department_led_sign_resolution_No_4314.pdf	Resolution No. 4314
📎 Transfer_of_Appropriations-BA-26-020.pdf	Budget Appropriation 26-020

RESOLUTION NO. 4314

A RESOLUTION OF THE CITY COUNCIL OF THE CITY OF COALINGA APPROVING A BUDGET ADJUSTMENT FOR THE FIRE DEPARTMENT LED SIGN

WHEREAS, on March 19, 2026, the City Council considered a staff report from the Fire Department recommending approval of a budget adjustment for installation of a programmable LED electronic message sign at the fire station; and

WHEREAS, the original sign design was previously approved as a one-time project on June 18, 2025, in the amount of \$25,000; and

WHEREAS, following a vehicle accident on July 29, 2025, which damaged the existing sign, the scope of the project was revised to replace the damaged structure with a larger monument-style LED sign; and

WHEREAS, the updated project includes a larger two-sided programmable LED display monument sign and replacement of current wall signage on the Elm Street side of the property; and

WHEREAS, the updated estimated cost of the project is approximately \$72,000, including \$62,409.70 for the two-sided monument sign and illuminated signs, \$2,981.15 for the electrical connection, and a 10% contingency; and

WHEREAS, the requested budget adjustment is approximately \$47,000; and

WHEREAS, the City Council finds that approval of the budget adjustment for the Fire Department LED sign is in the public interest and will enhance the City's ability to communicate time-sensitive public safety information, emergency notifications, recruitment messaging, and community engagement updates.

NOW, THEREFORE, BE IT RESOLVED BY THE CITY COUNCIL OF THE CITY OF COALINGA AS FOLLOWS:

1. The foregoing recitals are true and correct and are incorporated herein by this reference.
2. The City Council hereby approves a budget adjustment in the amount of approximately \$47,000 for the Fire Department LED sign project.
3. The City Manager, Finance Director, Fire Chief, and their designees are authorized to take all actions necessary to carry out the purpose of this Resolution.
4. This Resolution shall be effective as of its adoption.

PASSED AND ADOPTED by the City Council of the City of Coalinga at a regular meeting held on **April 2, 2026** by the following vote:

AYES:

NOES:

ABSENT:

ABSTAIN:

Nathan Vosburg, Mayor

ATTEST:

City Clerk



Budget Adjustment Form

BA No. 26-020

To: Financial Services Department
From: Fire Department
Contact Name: Greg DuPuis

Fiscal Year: FY25/26
Date: 3/19/2026
Resolution No: 4314

Type of Request: (Check one)

Budget Appropriation Transfer Receipt of Unanticipated Revenue

Project previously approved by City Council?

No Yes. Provide Approval Date: 18-Jun-25

ACTION

Transfer From	Budget Line	Description	Amount
		101-000-39500	General Fund- Fund Balance
Total:			47,000

Transfer To	Budget Line	Description	Amount
		101-416-98040	Major Machinery and Equipment
Total:			47,000

Totals in "Transfer FROM" and "Transfer TO" must match.

Justification of the Transfer (Required)

Council approved Fire Department LED sign one time project increase amount at the March 19, 2026 Council Meeting. Resolution and Budget Adjustment form going to Council on April 2, 2026.

Approvals

<p>Requested by:</p> <p> Department Head Signature</p> <p><input type="text" value="3/25/2026"/> Date</p>	<p>Reviewed & Approved by:</p> <p>Financial Services Department Date</p>
--	---

APPROVED by the City Council of the City of Coalinga, State of California,

this _____ day of _____ 20_____.

ATTEST: _____
City Clerk

Approved by: _____
City Manager Signature Date

**STAFF REPORT - CITY COUNCIL/SUCCESSOR AGENCY/PUBLIC FINANCE
AUTHORITY**

Subject: Consideration of Bid Award for Ramsey Park Splash Pad
Meeting Date: Thursday, April 2, 2026
From: Sean Brewer, City Manager
Prepared by: Jesse Barron, Assistant City Manager

I. RECOMMENDATION:

It is recommended that the Coalinga City Council award a contract in the amount of \$404,051.00 to Robbie's Construction for the Ramsey Park Splash Pad. It is also recommended that a contingency of 10% (\$40,405.10) be included in the Council action to cover any unforeseen incidentals for a total authorization amount of \$444,456.10.

II. BACKGROUND:

On April 21, 2022, the Coalinga City Council authorized funds for proposals for various phases of the Ramsey Park Splash Pad Project. The project includes a Splash Park, authorized on July 6, 2023, and a Bathroom & Shade Structure, both authorized on November 2, 2023. The Contractor will coordinate installation of these phases.

III. DISCUSSION:

City Staff received and opened 6 bids for this project on March 24, 2026, at 2:00pm. Robbie's Construction was the apparent low bidder with a total bid proposal of \$404,051.00. The Engineer's Estimate was \$314,300.00. The entire bid summary is included as Attachment "A". Robbie's Construction, has furnished the required bid bond. If the City Council decides to award the project to Robbie's Construction, and the "Notice to Proceed" is issued, the Contractor will have 48 working days to complete the work. The following is a tentative schedule:

Award of Contract: April 2, 2026
Start of Construction: April 20, 2026
Completion of Construction: June 25, 2026

IV. ALTERNATIVES:

The alternative to this council action would be to reject all bids. If all bids are rejected, the City would have to re-advertise or cancel the project. Staff believes that re-advertising the project will not result in lower bids.

V. FISCAL IMPACT:

Total authorization request for this contract is \$404,051.00 with an additional 10% contingency of \$40,405.10.00 for a total of \$444,456.10. This project is funded within the FY26 budget as a one-time project. This project is being funded by the General Fund.

ATTACHMENTS:

File Name

Description

- 📄 PW_25-001_Bid_Results.pdf
- 📄 PW_25-001_Bid_Summary.pdf

- Bid Results
- Bid Summary



CITY OF COALINGA
The Sunny Side of the Valley

Bid Results

City of Coalinga

Project Name: Ramsey Splash Park

Project No. : PW 25-001 / #3101

Bid Date: March 24, 2026

2:00 PM (D.S.T.), at Tri City Engineering Office

	Bidder	Base Bid
1	Robbies Construction	\$404,051.00
2	HBC Enterprises	\$447,482.08
3	Stockbridge General Contracting Inc	\$453,881.00
4	BDM Inc	\$509,694.20
5	Yanez Construction	\$629,711.00
6	GC Builders	\$695,328.00
7		
8		
9		

Robbies Construction Sub List

HBC Sub List

Phillips Electric - Coalinga Ca

HBC Enterprises JV - Clovis Ca

The Parkitects LLC - Fresno Ca

Signature Touch Landscape - Fresno Ca

King Khan Drilling and Construction - Clovis Ca

Fresno Seal and Stripe - Fresno Ca

Epic Land Surveying - Oakdale Ca

C3 Electric - Fresno Ca

Tri City Engineering
4630 W. Jennifer Ave., #101
Fresno, CA 93722-5415
Tel: 559.447.9075
Fax: 559.447-9074
info@tricityengineering.com

City of Coalinga
155 W. Durian Ave
Coalinga, CA 93210
Tel (559) 935-1533
Fax (559) 935-1184

Base Bid Items				1 Robbies Construction		2 HBC Enterprises		3 Stockbridge GC Inc.		4 BDM Inc.		5 Yanez Construction		6 GC Builders		
Item	Description	Unit	Qty.	Engineer's Est.	Unit Price	Extension	Unit Price	Extension	Unit Price	Extension	Unit Price	Extension	Unit Price	Extension	Unit Price	Extension
1	MOBILIZATION / GENERAL REQUIREMENTS	LS	1	\$ 15,450.00	\$ 15,650.00	\$ 15,650.00	\$ 27,600.46	\$ 27,600.46	\$ 25,500.00	\$ 25,500.00	\$ 20,000.00	\$ 20,000.00	\$ 15,000.00	\$ 15,000.00	\$ 12,500.00	\$ 12,500.00
2	WORKER SAFETY	LS	1	\$ 1,600.00	\$ 3,000.00	\$ 3,000.00	\$ 2,253.30	\$ 2,253.30	\$ 570.00	\$ 570.00	\$ 10,000.00	\$ 10,000.00	\$ 7,500.00	\$ 7,500.00	\$ 6,250.00	\$ 6,250.00
3	TRAFFIC CONTROL	LS	1	\$ 5,000.00	\$ 4,000.00	\$ 4,000.00	\$ 2,516.69	\$ 2,516.69	\$ 1,140.00	\$ 1,140.00	\$ 7,500.00	\$ 7,500.00	\$ 10,000.00	\$ 10,000.00	\$ 15,000.00	\$ 15,000.00
4	EROSION, SEDIMENT AND DUST CONTROL PLAN	LS	1	\$ 2,000.00	\$ 2,000.00	\$ 2,000.00	\$ 2,443.39	\$ 2,443.39	\$ 7,300.00	\$ 7,300.00	\$ 1,500.00	\$ 1,500.00	\$ 8,500.00	\$ 8,500.00	\$ 1,250.00	\$ 1,250.00
5	CONSTRUCTION SURVEYING	LS	1	\$ 4,500.00	\$ 14,700.00	\$ 14,700.00	\$ 11,308.46	\$ 11,308.46	\$ 14,400.00	\$ 14,400.00	\$ 10,000.00	\$ 10,000.00	\$ 15,000.00	\$ 15,000.00	\$ 12,575.00	\$ 12,575.00
6	ON-SITE SUBGRADE EXCAVATION, COMPACTION, AND GRADING	CY	207	\$ 10,350.00	\$ 34.78	\$ 7,200.00	\$ 104.75	\$ 21,683.25	\$ 125.00	\$ 25,875.00	\$ 265.00	\$ 54,855.00	\$ 90.00	\$ 18,630.00	\$ 286.88	\$ 59,384.16
7	RESTROOM INSTALLATION, FLOORING & FURNISHINGS	LS	1	\$ 8,000.00	\$ 15,000.00	\$ 15,000.00	\$ 23,518.57	\$ 23,518.57	\$ 12,200.00	\$ 12,200.00	\$ 35,000.00	\$ 35,000.00	\$ 37,000.00	\$ 37,000.00	\$ 31,250.00	\$ 31,250.00
8	SITE & BUILDING ELECTRICAL INSTALLATION	LS	1	\$ 24,000.00	\$ 46,891.00	\$ 46,891.00	\$ 37,654.97	\$ 37,654.97	\$ 50,000.00	\$ 50,000.00	\$ 72,000.00	\$ 72,000.00	\$ 40,000.00	\$ 40,000.00	\$ 51,113.75	\$ 51,113.75
9	SHADE STRUCTURE CONCRETE SLAB	SF	1970	\$ 29,550.00	\$ 12.18	\$ 24,000.00	\$ 11.27	\$ 22,201.90	\$ 13.50	\$ 26,595.00	\$ 7.00	\$ 13,790.00	\$ 35.00	\$ 68,950.00	\$ 20.00	\$ 39,400.00
10	SHADE STRUCTURE CONCRETE COLUMN	EA	10	\$ 20,000.00	\$ 3,800.00	\$ 38,000.00	\$ 2,608.70	\$ 26,087.00	\$ 3,200.00	\$ 32,000.00	\$ 2,500.00	\$ 25,000.00	\$ 4,000.00	\$ 40,000.00	\$ 4,375.00	\$ 43,750.00
11	ON-SITE 4" CONCRETE SIDEWALK	SF	3844	\$ 38,440.00	\$ 8.22	\$ 31,600.00	\$ 11.27	\$ 43,321.88	\$ 11.50	\$ 44,206.00	\$ 10.00	\$ 38,440.00	\$ 13.00	\$ 49,972.00	\$ 23.75	\$ 91,295.00
12	ON-SITE AGGREGATE BASE CLASS II	TON	85	\$ 2,975.00	\$ 60.00	\$ 5,100.00	\$ 241.10	\$ 20,493.50	\$ 95.50	\$ 8,117.50	\$ 55.00	\$ 4,675.00	\$ 85.00	\$ 7,225.00	\$ 130.00	\$ 11,050.00
13	FONROCHE SOLAR LIGHT FOUNDATION AND INSTALLATION	EA	2	\$ 4,000.00	\$ 5,000.00	\$ 10,000.00	\$ 8,707.88	\$ 17,415.76	\$ 3,900.00	\$ 7,800.00	\$ 6,000.00	\$ 12,000.00	\$ 9,800.00	\$ 19,600.00	\$ 9,661.25	\$ 19,322.50
14	TRASH RECEPTACLE INSTALLATION	EA	2	\$ 500.00	\$ 600.00	\$ 1,200.00	\$ 563.33	\$ 1,126.66	\$ 2,600.00	\$ 5,200.00	\$ 500.00	\$ 1,000.00	\$ 450.00	\$ 900.00	\$ 625.00	\$ 1,250.00
15	8" STEEL PICNIC TABLE INSTALLATION	EA	1	\$ 500.00	\$ 1,000.00	\$ 1,000.00	\$ 563.33	\$ 563.33	\$ 7,900.00	\$ 7,900.00	\$ 750.00	\$ 750.00	\$ 450.00	\$ 450.00	\$ 937.50	\$ 937.50
16	GARDEN BENCH INSTALLATION	EA	2	\$ 500.00	\$ 700.00	\$ 1,400.00	\$ 563.33	\$ 1,126.66	\$ 320.00	\$ 640.00	\$ 750.00	\$ 1,500.00	\$ 650.00	\$ 1,300.00	\$ 750.00	\$ 1,500.00
17	6" STEEL CAST BENCH INSTALLATION	EA	2	\$ 500.00	\$ 600.00	\$ 1,200.00	\$ 563.33	\$ 1,126.66	\$ 2,900.00	\$ 5,800.00	\$ 600.00	\$ 1,200.00	\$ 550.00	\$ 1,100.00	\$ 625.00	\$ 1,250.00
18	PERMANENT SIGN INSTALLATION	LS	1	\$ 1,500.00	\$ 2,500.00	\$ 2,500.00	\$ 1,126.65	\$ 1,126.65	\$ 1,130.00	\$ 1,130.00	\$ 12,500.00	\$ 12,500.00	\$ 3,500.00	\$ 3,500.00	\$ 1,000.00	\$ 1,000.00
19	ROCK CHIP INSTALLATION	CY	28	\$ 2,100.00	\$ 239.29	\$ 6,700.00	\$ 147.03	\$ 4,116.84	\$ 130.00	\$ 3,640.00	\$ 150.00	\$ 4,200.00	\$ 105.00	\$ 2,940.00	\$ 190.05	\$ 5,321.40
20	ROLLED TIFTUF BERMUDA SOD AND INSTALLATION	SF	5542	\$ 16,626.00	\$ 5.23	\$ 29,000.00	\$ 2.37	\$ 13,134.54	\$ 3.50	\$ 19,397.00	\$ 2.70	\$ 14,963.40	\$ 5.00	\$ 27,710.00	\$ 2.86	\$ 15,850.12
21	TURF SPRINKLERS	EA	79	\$ 1,264.00	\$ 37.97	\$ 3,000.00	\$ 68.17	\$ 5,385.43	\$ 23.00	\$ 1,817.00	\$ 108.00	\$ 8,532.00	\$ 250.00	\$ 19,750.00	\$ 113.58	\$ 8,972.82
22	24-INCH BOX TREES INSTALLATION	EA	4	\$ 1,400.00	\$ 909.83	\$ 3,600.00	\$ 309.83	\$ 1,239.32	\$ 635.00	\$ 2,540.00	\$ 545.00	\$ 2,180.00	\$ 550.00	\$ 2,200.00	\$ 569.69	\$ 2,278.76
23	TREE WATERING SYSTEM WITH BUBBLER	EA	4	\$ 600.00	\$ 575.00	\$ 2,300.00	\$ 433.76	\$ 1,735.04	\$ 300.00	\$ 1,200.00	\$ 110.00	\$ 440.00	\$ 850.00	\$ 3,400.00	\$ 116.61	\$ 466.44
24	IRRIGATION SERVICE, VALVE ASSEMBLIES, AND CONTROLLER WITH CAGE	EA	2	\$ 8,000.00	\$ 6,750.00	\$ 13,500.00	\$ 3,210.95	\$ 6,421.90	\$ 6,000.00	\$ 12,000.00	\$ 10,000.00	\$ 20,000.00	\$ 5,500.00	\$ 11,000.00	\$ 6,236.26	\$ 12,472.52
25	1 1/2" SCH. 40 PVC IRRIGATION LINE	LF	465	\$ 4,650.00	\$ 6.88	\$ 3,200.00	\$ 6.78	\$ 3,152.70	\$ 8.75	\$ 4,068.75	\$ 1.50	\$ 697.50	\$ 20.00	\$ 9,300.00	\$ 1.56	\$ 725.40
26	1" SCH. 40 PVC IRRIGATION LINE	LF	340	\$ 2,720.00	\$ 5.88	\$ 2,000.00	\$ 6.76	\$ 2,298.40	\$ 8.50	\$ 2,890.00	\$ 1.20	\$ 408.00	\$ 15.00	\$ 5,100.00	\$ 1.25	\$ 425.00
27	3/4" SCH. 40 PVC IRRIGATION LINE	LF	683	\$ 4,098.00	\$ 4.98	\$ 3,400.00	\$ 6.76	\$ 4,617.08	\$ 6.50	\$ 4,439.50	\$ 1.10	\$ 751.30	\$ 13.00	\$ 8,879.00	\$ 0.94	\$ 642.02
28	1/2" SCH. 40 PVC IRRIGATION LINE	LF	275	\$ 1,375.00	\$ 4.00	\$ 1,100.00	\$ 6.76	\$ 1,859.00	\$ 8.50	\$ 2,337.50	\$ 0.80	\$ 220.00	\$ 10.00	\$ 2,750.00	\$ 0.81	\$ 222.75
29	ROUGH SEWER & WATER PLUMBING	LS	1	\$ 20,000.00	\$ 14,200.00	\$ 14,200.00	\$ 11,192.14	\$ 11,192.14	\$ 17,000.00	\$ 17,000.00	\$ 22,500.00	\$ 22,500.00	\$ 37,500.00	\$ 37,500.00	\$ 62,500.00	\$ 62,500.00
30	PURCHASE AND INSTALL FLOOR DRAINS	EA	5	\$ 1,800.00	\$ 600.00	\$ 3,000.00	\$ 1,571.90	\$ 7,859.50	\$ 830.00	\$ 4,150.00	\$ 1,750.00	\$ 8,750.00	\$ 1,500.00	\$ 7,500.00	\$ 1,500.00	\$ 7,500.00
31	STORM DRAIN INLETS	EA	2	\$ 2,400.00	\$ 4,000.00	\$ 8,000.00	\$ 2,478.30	\$ 4,956.60	\$ 700.00	\$ 1,400.00	\$ 1,500.00	\$ 3,000.00	\$ 2,200.00	\$ 4,400.00	\$ 8,125.00	\$ 16,250.00
32	SHADE STRUCTURE INSTALLATION	LS	1	\$ 19,050.00	\$ 29,000.00	\$ 29,000.00	\$ 30,672.85	\$ 30,672.85	\$ 30,400.00	\$ 30,400.00	\$ 27,500.00	\$ 27,500.00	\$ 40,000.00	\$ 40,000.00	\$ 36,250.00	\$ 36,250.00
33	OFF-SITE EXCAVATION, GRADING, & COMPACTING	CY	90	\$ 4,500.00	\$ 40.00	\$ 3,600.00	\$ 101.40	\$ 9,126.00	\$ 105.00	\$ 9,450.00	\$ 55.00	\$ 4,950.00	\$ 95.00	\$ 8,550.00	\$ 65.00	\$ 5,850.00
34	OFF-SITE AC PAVEMENT AND CONCRETE REMOVAL AND DISPOSAL	CY	54	\$ 6,480.00	\$ 83.33	\$ 4,500.00	\$ 319.43	\$ 17,249.22	\$ 180.00	\$ 9,720.00	\$ 180.00	\$ 9,720.00	\$ 75.00	\$ 4,050.00	\$ 237.50	\$ 12,825.00
35	OFF-SITE HOT MIX ASPHALT TYPE A (HMA-A)	TON	7	\$ 980.00	\$ 357.14	\$ 2,500.00	\$ 1,063.46	\$ 7,444.22	\$ 490.00	\$ 3,430.00	\$ 1,050.00	\$ 7,350.00	\$ 650.00	\$ 4,550.00	\$ 1,283.75	\$ 8,986.25
36	OFF-SITE AGGREGATE BASE CLASS II	TON	21	\$ 735.00	\$ 60.00	\$ 1,260.00	\$ 241.43	\$ 5,070.03	\$ 112.00	\$ 2,352.00	\$ 100.00	\$ 2,100.00	\$ 120.00	\$ 2,520.00	\$ 228.13	\$ 4,790.73
37	OFF-SITE 6" CURB & GUTTER	LF	100	\$ 4,000.00	\$ 65.00	\$ 6,500.00	\$ 33.80	\$ 3,380.00	\$ 47.75	\$ 4,775.00	\$ 85.00	\$ 8,500.00	\$ 120.00	\$ 12,000.00	\$ 37.50	\$ 3,750.00
38	OFF-SITE 4" THICK CONCRETE SIDEWALK	SF	2360	\$ 23,600.00	\$ 7.97	\$ 18,800.00	\$ 11.27	\$ 26,597.20	\$ 11.50	\$ 27,140.00	\$ 10.00	\$ 23,600.00	\$ 13.00	\$ 30,680.00	\$ 23.75	\$ 56,050.00
39	OFF-SITE CONCRETE CURB RAMP	SF	117	\$ 3,510.00	\$ 51.28	\$ 6,000.00	\$ 16.90	\$ 1,977.30	\$ 14.75	\$ 1,725.75	\$ 10.00	\$ 1,170.00	\$ 45.00	\$ 5,265.00	\$ 31.25	\$ 3,656.25
40	OFF-SITE CONCRETE DRIVEWAY APPROACH	SF	212	\$ 5,300.00	\$ 25.00	\$ 5,300.00	\$ 17.14	\$ 3,633.68	\$ 13.75	\$ 2,915.00	\$ 21.00	\$ 4,452.00	\$ 45.00	\$ 9,540.00	\$ 31.25	\$ 6,625.00
41	ADA DETECTABLE WARNING TILE (3'X4')	EA	4	\$ 1,400.00	\$ 350.00	\$ 1,400.00	\$ 563.33	\$ 2,253.32	\$ 625.00	\$ 2,500.00	\$ 600.00	\$ 2,400.00	\$ 1,500.00	\$ 6,000.00	\$ 625.00	\$ 2,500.00
42	TRAFFIC MARKINGS, STRIPING, & SIGNAGE	LS	1	\$ 2,830.00	\$ 3,000.00	\$ 3,000.00	\$ 3,468.06	\$ 3,468.06	\$ 4,000.00	\$ 4,000.00	\$ 4,100.00	\$ 4,100.00	\$ 8,500.00	\$ 8,500.00	\$ 4,402.50	\$ 4,402.50
43	UTILITY DEMO & IMPROVEMENTS															
44	ADJUST UTILITY LID	EA	2	\$ 2,500.00	\$ 300.00	\$ 600.00	\$ 281.66	\$ 563.32	\$ 240.00	\$ 480.00	\$ 500.00	\$ 1,000.00	\$ 1,500.00	\$ 3,000.00	\$ 937.50	\$ 1,875.00
45	SIDEWALK STORM UNDERDRAIN	LS	1	\$ 2,400.00	\$ 3,500.00	\$ 3,500.00	\$ 3,379.95	\$ 3,379.95	\$ 1,170.00	\$ 1,170.00	\$ 4,000.00	\$ 4,000.00	\$ 1,500.00	\$ 1,500.00	\$ 9,750.00	\$ 9,750.00
46	ADA SIGN WITH POST AND CONCRETE FOOTING	EA	1	\$ 450.00	\$ 650.00	\$ 650.00	\$ 1,126.65	\$ 1,126.65	\$ 570.00	\$ 570.00	\$ 500.00	\$ 500.00	\$ 6,500.00	\$ 6,500.00	\$ 1,000.00	\$ 1,000.00
Base Bid Summary				\$ 314,133.00	\$ 650.00	\$ 404,051.00	\$ 447,482.08	\$ 447,482.08	\$ 453,881.00	\$ 509,694.20	\$ 509,694.20	\$ 629,711.00	\$ 629,711.00	\$ 695,315.87	\$ 695,315.87	\$ 695,315.87
Written Words (Governs)						\$ 404,051.00	\$ 447,482.08	\$ 447,482.08	\$ 453,881.00	\$ 509,694.20	\$ 509,694.20	\$ 629,711.00	\$ 629,711.00	\$ 695,315.87	\$ 695,315.87	\$ 695,315.87

**STAFF REPORT - CITY COUNCIL/SUCCESSOR AGENCY/PUBLIC FINANCE
AUTHORITY**

Subject: Adopt Resolution No. 4315 in Support of the Better Roads, Safe Streets
Transportation Measure
Meeting Date: Thursday, April 2, 2026
From: Sean Brewer, Interim City Manager
Prepared by: Jesse Barron, Assistant City Manager

I. RECOMMENDATION:

Adopt Resolution No. 4315, approving the support of the Fresno County Transportation Improvement Act (Better Roads, Safe Street) Transportation Measure.

This item was requested as a Future Agenda Item by Councilman Vosburg.

II. BACKGROUND:

The Fresno County Transportation Improvement Act ("Better Roads, Safe Streets") is a proposed 30-year, approximately \$7.5 billion measure for the 2026 ballot aimed at replacing the expiring Measure C. It prioritizes fixing local streets, filling potholes, enhancing safety, and improving public transit through a 0.5% sales tax, dedicating 65% of funds to local road repairs and 25% to transit.

III. DISCUSSION:

Key Features of the "Better Roads, Safe Streets" Proposal:

- Focus on Safety: Aims to reduce crashes and improve safety for drivers, cyclists, and pedestrians through better intersection designs, traffic signals, and lighting.
- Accountability & Equity: Targets resources toward neighborhoods with the worst roads and ensures a \$400,000 minimum annual funding floor for smaller, rural cities.
- Support: Backed by a coalition of community groups, including Fresno Building Healthy Communities and Fresno DRIVE.
- Comparison: This is a competing measure against the "Fix Our Roads" plan, focusing more on local repair rather than large-scale highway expansion.

The initiative aims to address billions in deferred maintenance and provide safer, better-connected streets for Fresno County residents by replacing Measure C after its expiration in 2027.

IV. ALTERNATIVES:

Do not support the Fresno County Transportation Improvement Act (Better Roads, Safe Street)

Transportation Measure.

V. FISCAL IMPACT:

None.

ATTACHMENTS:

File Name	Description
📎 Resolution_4315_Better_Roads_Safe_Streets.v1.pdf	Resolution No 4315

RESOLUTION NO. 4315

A RESOLUTION OF THE CITY COUNCIL OF THE CITY OF CITY OF COALINGA IN SUPPORT OF THE *BETTER ROADS, SAFE STREETS* TRANSPORTATION MEASURE

WHEREAS, safe, reliable, and well-maintained local transportation infrastructure is fundamental to the public health, safety, economic vitality, and overall quality of life of residents in Fresno County, particularly in small and rural communities; and

WHEREAS, local streets, neighborhood roads, sidewalks, bike paths, and transit facilities are the infrastructure most directly used by residents every day—connecting families to schools, jobs, healthcare, and essential services—yet many of these assets are aging, underfunded, and in urgent need of repair; and

WHEREAS, unsafe local road conditions disproportionately impact children, seniors, people with disabilities, and low-income residents, underscoring the need for intentional investments in Safe Routes to Schools, pedestrian safety, traffic calming, and improved access to public transit; and

WHEREAS, locally controlled transportation funding is essential to ensuring that revenues generated within Fresno County are reinvested back into the communities that rely on them, rather than diverted primarily toward state-owned highways or infrastructure that does not directly serve local jurisdiction needs; and

WHEREAS, the Better Roads, Safe Streets campaign is a broad, community-led coalition working collaboratively with cities, residents, labor, business, and community organizations to develop a transportation investment plan that reflects local priorities, equity, and long-term sustainability; and

WHEREAS, the Fresno County Transportation Improvement Act proposes the continuation of an existing half-cent transportation sales tax for 30 years—without increasing the current tax rate—generating an estimated \$7.4 billion dedicated to repairing local roads, improving transit reliability, enhancing walking and bicycling safety, expanding Safe Routes to Schools, and supporting transportation improvements across Fresno County; and

WHEREAS, the proposed plan prioritizes local street and road maintenance first, while also strengthening public transit, improving countywide connectivity, and ensuring transportation investments equitably serve both urban and rural communities; and

WHEREAS, the proposed plan emphasizes strong local control, requiring that funds be allocated and expended in accordance with voter-approved categories and local project lists, supported by clear performance metrics, measurable outcomes, and regular public reporting to track progress and effectiveness; and

WHEREAS, robust and independent oversight mechanisms—including citizen oversight, fiscal audits, and transparency requirements—are critical to ensuring that all transportation revenues are used exactly as voters intend, safeguarding public trust and accountability; and

WHEREAS, the 30-year measure includes formal evaluations at each 10-year interval to assess whether transportation investments are meeting identified local and countywide needs, to measure performance against adopted outcomes, and to evaluate and respond to changing transportation demands identified by cities and local jurisdictions, while remaining consistent with voter-approved intent; and

WHEREAS, sustained, locally directed transportation investment is essential to improving emergency response times, reducing traffic injuries and fatalities, supporting economic development, and ensuring safe, accessible mobility for all residents of Fresno County.

NOW, THEREFORE, BE IT RESOLVED, that the City Council of the **City of the City of Coalinga** hereby supports the Better Roads, Safe Streets campaign and its proposed Fresno County Transportation Improvement Act, and grants use of the official city name for the effort, and those councilmembers who vote in support, and affirms its

commitment to placing local communities, neighborhood safety, children’s routes to school, strong local control, measurable outcomes, meaningful oversight, and adaptive long-term planning at the center of Fresno County’s transportation investments.

I hereby certify that the foregoing resolution was duly passed and adopted by the City Council of the City of Coalinga at a regular meeting on this **2nd day of April, 2026**, by the following vote:

AYES:

NOES:

ABSTAIN:

ABSENT:

APPROVED:

Nathan Vosburg, Mayor

ATTEST:

Shannon Jensen, City Clerk

**STAFF REPORT - CITY COUNCIL/SUCCESSOR AGENCY/PUBLIC FINANCE
AUTHORITY**

Subject: Adopt Resolution No. 4316 and Consideration of Approval of the Transfer of Appropriation No. 26-021 for a One Time Project of 2 Submersible Pumps for Sandalwood Lift Station for Fiscal Year 2025-2026

Meeting Date: Thursday, April 2, 2026

From: Sean Brewer, Interim City Manager

Prepared by: Jesse Barron, Assistant City Manager

I. RECOMMENDATION:

City Manager and Financial Services Director recommends City Council to:

1. Adopt Resolution No. 4316 – Amending the FY25/26 Operating and Capital Budget
2. Consideration of approval of the Transfer of Appropriations No. 26-021 in the amount of \$35,000.00.

II. BACKGROUND:

The submersible pumps at the Sandalwood lift station were installed in 1992 and have a life expectancy of 10-20 years. The submersible pumps at the Sandalwood lift station have been rebuilt several times throughout the years, the last time as early as March 2024.

III. DISCUSSION:

The submersible pumps are crucial for operating and pumping all sewer from the Sandalwood neighborhood to the sewer plant. The pumps have outlasted their life expectancy of 10-20 years and we are currently operating in an emergency situation using rented pumps pumping in a bypass method.

Two New Submersible Pumps are a one-time project for FY 25/26 with \$60,000 allocated. The quote received is for \$93,208.50 which is a difference of 32,208.50. Staff is requesting an additional \$35,000 to cover the cost of the parts as well as any additional shipping costs not reflected in the attached quote.

IV. ALTERNATIVES:

Not approve appropriation transfer.

V. FISCAL IMPACT:

This will impact the Wastewater Enterprise Fund-Fund Balance by reducing it by \$35,000 to cover the additional cost. The budget for account 503-521-98040 will be amended from \$108,300 to \$133,300.

ATTACHMENTS:

File Name	Description
 Submersible_Pump_Quote.pdf	Quote

▢ RESO#4316_ApprovingFY25-26_Budget_Adj_TOA#26-021-Submersible_Pumps_for_Sandalwood_Lift_Station_040226_.pdf

Resolution No 4316

▢ 20260402-26-021-2_Submersible_Pumps-Transfer_of_Appropriation.pdf

Transfer Of
Appropriation



SANITATION • HYDRAULIC • AND PROCESSING EQUIPMENT

PLEASANTON

SACRAMENTO

STOCKTON

3825 Hopyard Road #195
Pleasanton, CA 94588
Phone (925) 485-9720

2356 Gold Meadow Way #270
Gold River, CA 95670
Phone (916) 309-4132

119 Val Dervin Parkway # 2
Stockton, CA 95206
Phone (209) 234-5909

QUOTATION

TO:	City of Coalinga	DATE:	03-18-2026
		QUOTE #:	138908
		DESC:	
		JOB:	City of Coalinga (CP 3152 Replacements - NP3171)
		LOCATION:	
ATTN:	Eric DeLeon	PHONE:	
		EMAIL:	
WE ARE PLEASED TO QUOTE ON THE FOLLOWING EQUIPMENT SUBJECT TO CONDITIONS PRINTED ON LAST PAGE HEREOF, THESE CONDITIONS MAY BE CHANGED ONLY BY A WRITTEN STATEMENT SIGNED BY AN OFFICER OF SHAPE, INCORPORATED.		<input checked="" type="checkbox"/> F.O.B. FACTORY <input type="checkbox"/> F.F.A. TO FIRST DESTINATION	

Line #	Qty	Item	Price
01	2	Flygt NP3171 HT3 ~455 (25hp/460v/3ph) 4" Discharge, FM Explosion Proof, FLS, 65' Power Cable	
02	2	Spacer Block Kit (4" to 6")	
03	1	Freight	
Total for Above Equipment:			\$85,532.00
(Tax Rate 8.975%) Total Tax:			\$7,676.50
Grand Total:			\$93,208.50

Notes:

- QUOTE IS VALID FOR 45 DAYS, See attached TOCs for details
- Price DOES NOT INCLUDE ANY APPLICABLE TAXES
- Price INCLUDES Freight: F.F.A.
- Price does not include: installation, equipment unloading, pipe, conduit, anchor bolts, guide bars/rails or any other items not listed.
- ESTIMATED EQUIPMENT LEAD TIME: A) Pumps 12-14 WEEKS B) ACCESSORIES 10-12 WEEKS

SHAPE, INC.
Sean Smith - ssmith@shapecal.com

QUOTATION DOES NOT INCLUDE ANY SALES OR USE TAX PAYABLE UNDER ANY STATE OR FEDERAL STATURE. THIS QUOTATION PRICE IS FOR MATERIAL LISTED ABOVE. ANY ADDITIONS OR MODIFICATIONS THAT BECOME NECESSARY FOR APPROVED SUBMITTALS, UPON AWARDING OF THIS CONTRACT, MAY RESULT IN NECESSARY PRICE CHANGES.

NOTE: ITEMS NOT SPECIFIED ON THIS QUOTATION ARE NOT INCLUDED IN OUR PRICE AND ARE TO BE SUPPLIED BY OTHERS. PRICES ARE FOR IMMEDIATE ACCEPTANCE AND SUBJECT TO CHANGE WITHOUT NOTICE. SALE SUBJECT TO MANUFACTURERS STANDARD TERMS AND CONDITIONS. 30% RE-STOCKING FEE.

SHAPE STANDARD TERMS AND CONDITIONS

ACCEPTANCE

The following Terms and Conditions are an integral part of the offer to sell the equipment and/or services offered in this proposal. When the BUYER signifies acceptance of this quotation by submission of a Purchase Order or signed SELLER Quotation, it shall become a binding contract when accepted and signed by an authorized signer of the SELLER. Any changes or amendments to this proposal made by the BUYER must have SELLER's approval in writing to become a part of this contract. These Terms and Conditions and the accompanying Purchase Order or signed SELLER Quotation shall comprise the entire agreement between the parties and no course of prior dealings between the parties and no usage of the trade shall be relevant to supplement or explain any terms used in this contract. Unless stated otherwise, the terms and conditions of the manufacturers listed herein will apply to this quotation. Any attachments or listed documents are considered a part of this quotation and are made part of the agreement. **Quote is firm for thirty (30) days unless otherwise stated on the face of the attached quotation.**

APPROVAL DRAWINGS

All items listed are based on SELLER'S interpretation of the requirements in accordance with the plans and specifications. Any preliminary drawings or literature attached to our quotation are for illustration purposes only to show approximate arrangements. Specific drawings and submittal data will be furnished for approval as required after receipt and acceptance of the BUYER'S order. Any submittal or manuals when provided by SELLER will be in the form of a PDF electronic file only. Any form of media beyond the electronic file would be the responsibility of BUYER. Fabrication of products or equipment ordered will not begin until approval and direction to proceed is received in writing. No warranty is made regarding quantities, materials of construction or type of materials quoted. Operation, installation, and maintenance of materials quoted are the responsibility of the OWNER or CONTRACTOR.

DELIVERY

Any shipment or delivery date recited represents our best estimate, but no liability, direct or indirect, is assumed by SELLER for failure to ship or deliver on such dates. Unless otherwise directed, SELLER shall have the right to make early or partial shipments and invoices covering the same to BUYER shall be due and payable in accordance with payment terms hereof. FOB shall be origin unless stated otherwise on the front of these Terms and Conditions. Delivery schedule(s) will be contingent on supply-chain availability and variability for material components, therefore, lead-times are subject to change without notice. Published weights are careful estimates but are not guaranteed. SELLER will endeavor, insofar, as it is possible, to comply with shipping instructions specified by the Purchaser. However, SELLER reserves the right to ship merchandise by such means of transportation as it may select. The manufacturer will ship the equipment via best way. Demurrage shall be billed to the account of the Purchaser. **DAMAGE CLAIMS:** Care is taken in packaging all shipments. After BUYER has been given the receipt by the transportation company, all claims for breakage or shortages, whether concealed or obvious, must be made in writing by the BUYER to the carrier and SELLER within seven (7) days after receipt of shipment. When damage or shortages are obvious, written comments on the bill of lading are required before the driver is released. **RETURNED PRODUCTS:** In no instance is equipment to be returned without first obtaining SELLER'S written approval and returned materials authorization. If shipment is postponed at the request of the purchaser after manufacturing has been commenced, payment will be due on notice from us that the equipment is ready for shipment. Pro rata payments shall be made for partial shipments.

STORAGE

Any item of the product on which shipment is delayed by BUYER may be placed in storage by SELLER at BUYER'S expense and risk. If a delay in shipment is requested by BUYER after an order has been entered and accepted:

- a. No charge will be made if the request for delay is made more than six (6) weeks before acknowledged shipping date and the requested delay is for a period not in excess of thirty (30) days.
- b. A charge will be made if the requested delay exceeds a period of thirty (30) days or if the request is made within six (6) weeks of the acknowledged shipping date. SELLER will advise BUYER of the charge within ten (10) days of receiving BUYER'S request for delay.
- c. If the product is within six (6) weeks of the acknowledged shipping date, then SELLER has the option of completing, invoicing and storing the product and charging one and one-half percent (1.5%) per month, or the maximum percentage permitted by law, whichever is lesser, of the established price for such product, plus storage cost.

PAYMENT

Payment terms, upon credit approval, are of net thirty (30) days from the date of each invoice for material shipped (or when ready for shipment if shipment is deferred by BUYER) **unless stated otherwise on the face of the attached quotation.** Flow down provisions are not accepted and shall not be enforceable against SELLER. Retention is not allowed. In the event any payment becomes past due, a charge of one-half percent (1.5%) will be assessed monthly. These terms are completely independent from, and not contingent upon, when BUYER receives payment from the OWNER. A processing fee of up to four percent (4%) will be added for credit card payments. All merchandise sold is subject to lien laws. Partial or final payment shall constitute acceptance of delivered materials, products, or equipment.

FORCE MAJEURE

Neither Party will be liable for any failure or delay in performing an obligation under these Terms and Conditions that is due to any of the following causes, to the extent beyond its reasonable control: acts of God, accident, riots, war, terrorist act, epidemic, pandemic, quarantine, civil commotion, breakdown of communication facilities, breakdown of web host, breakdown of internet service provider, natural catastrophes, governmental acts or omissions, changes in laws or regulations, national strikes, fire, explosion, generalized lack of availability of raw materials or energy. For the avoidance of doubt, Force Majeure shall not include (a) financial distress nor the inability of either party to make a profit or avoid a financial loss, (b) changes in market prices or conditions, or (c) a party's financial inability to perform its obligations hereunder.

TAXES AND BONDS

Taxes and bonds are **NOT** included in our pricing. Any applicable taxes or bonds will be added to the price and shown separately on each invoice. All prices exclude sales, use, duties, excise, and other taxes in respect to manufacture, sale, or delivery, all of which are to be paid by the buyer unless a proper exemption certificate is furnished. BUYER agrees to reimburse our company for taxes SELLER must pay on BUYER'S behalf.

PRICE ESCALATION and/or MATERIAL DEPOSITS

If between the proposal date and actual procurement and through no fault of the SELLER, the relevant cost of labor, material, freight, brokerage fees, tariffs, and other SELLER costs combined relating to the contract increase, then the contract price shall be subject to escalation and increased accordingly. If required by the BUYER, increase shall be verified by documentation and the amount of contract price escalation shall be calculated as either the actual increased cost to the Seller or, if agreed by the Parties, the equivalent increase of a relevant industry recognized third-party index. SELLER shall undertake good faith efforts to obtain savings in its procurement of materials to avoid escalation costs. BUYER shall cooperate with SELLER in such efforts to obtain such cost savings. SELLER shall contemporaneously track any escalation costs.

CLAIMS AND BACKCHARGES

BUYER agrees to examine all materials immediately upon delivery and report to SELLER in writing any defects or shortages noted no later than ten (10) days following the date of receipt. The parties agree that if no such claim is made within said time, it shall be considered acceptable and in good order with respect to any defect or shortage which would have been revealed by such an inspection. In no event will SELLER be responsible for any charge for modification, servicing, adjustment or for any other expense without written authorization from SELLER prior to the performance of any such work. **IN NO EVENT SHALL SELLER BE LIABLE TO BUYER OR**

SHAPE STANDARD TERMS AND CONDITIONS**2**

ANY THIRD PARTY FOR ANY LOSS OF USE, REVENUE OR PROFIT, OR FOR CONSEQUENTIAL, INDIRECT, INCIDENTAL, SPECIAL, EXEMPLARY, OR PUNITIVE DAMAGES, FOR ANY REASON, INCLUDING WITHOUT LIMITATION, DAMAGES ARISING OUT OF A DELAY IN OR FAILURE OF DELIVERY, DEFECTS IN MATERIAL AND WORKMANSHIP AND/OR FAILURE OF GOODS TO PERFORM TO APPLICABLE SPECIFICATIONS, DRAWINGS, BLUEPRINTS OR SAMPLES AS SET FORTH OR DESCRIBED HEREIN, IF ANY, OF A BREACH BY SELLER OF ANY OTHER TERM OR OBLIGATION OF SELLER UNDER THE CONTRACT. No penalty clauses of any description will be effective unless approved in writing over the signature of a principal of SELLER. Under no circumstances shall SELLER be liable for any consequential, special or incidental damages, including liquidated damages, arising from any breach by it in this transaction, AND ALL SUCH CONSEQUENTIAL, SPECIAL AND INCIDENTAL DAMAGES, INCLUDING LIQUIDATED DAMAGES, ARE EXCLUDED FROM ANY REMEDIES AVAILABLE TO THE BUYER.

SECURITY INTEREST & TITLE

Until all amounts due SELLER have been paid in full, SELLER shall retain a security interest in the product and have all rights of a secured party under the Uniform Commercial Code and applicable law, including the right to repossess the product or equipment without legal process and the right to require the BUYER to assemble the equipment and make it available to SELLER at a place reasonably convenient to both parties.

WARRANTY

Equipment and parts not manufactured by the SELLER carry only the warranty of the manufacturer of said parts. SELLER does not make any express or implied warranty for equipment and/or parts it did not manufacture. Credits for defective material and workmanship in said equipment and/or parts are only in accordance with the underlying company policy of the manufacturer. SELLER makes no warranty whatsoever with respect to any equipment and/or parts as to their merchantability or fitness for a particular purpose. It is further agreed that the SELLER assumes no liability whatsoever for failure of equipment due to normal usage and wear.

INDEMNIFICATION

To the fullest extent permitted by the law in which the project is located, BUYER and SELLER shall indemnify and hold one another and their respective employees and agents harmless from and against all claims, damages, losses, liabilities, actions, causes of action, demands, fines, penalties, judgments, costs, and expenses, including but not limited to attorneys' fees, court costs, expert fees and costs, arising out of or resulting from BUYER's or SELLER's own negligent acts, omissions or misconduct, to the extent such negligence is covered by BUYER's and SELLER's respective insurance policies. In the event any third party asserts against SELLER a claim for patent infringement, royalties or licensing fees with respect to BUYER's use of the products, materials, or equipment provided hereunder, BUYER agrees to indemnify SELLER for all liability damages, costs and expenses in connection therewith.

CANCELLATION

Buyer may cancel this contract only in writing signed by BUYER's duly authorized agent and acknowledged in writing by SELLER's duly authorized agent. Should this order be cancelled, BUYER shall be obligated to pay for the level of work performed and products shipped. Work performed includes any engineering, calculations, preparation of submittals, drawings, and/or travel to job site in relation to this order. In addition to any other remedies provided under these Terms and Conditions, SELLER may terminate this contract with immediate effect by providing signed, written notice to BUYER, if BUYER: (i) fails to pay any amount when due under the contract and such failure continues for 30 days after BUYER's receipt of written notice of nonpayment; (ii) has not otherwise performed or complied with any of these Terms and Conditions; or (iii) becomes insolvent, files a petition for bankruptcy or commences or has commenced against it proceedings in bankruptcy, receivership, reorganization or assignment for the benefit of creditors.

FIELD WORK

Unless specifically stated on our quotation, installation, start-up service, field testing, supervision, operation, and training are not included in our pricing of product. In the event that SELLER or any of its employees or agents do perform work or services on-site at the project's location, BUYER agrees to hold SELLER and its employees or agents harmless for any injuries or damage to property caused by their acts or omission, except to the extent said injuries or property damage arise from gross negligence or intentional misconduct.

MODIFICATIONS

This contract can be modified only in writing which specifically states that it amends these Terms and Conditions and is signed by both parties and their duly authorized agents. It is further agreed that this contract shall not be modified in any respect except in writing signed by the party and their duly authorized agent against whom the modification is sought to be enforced.

AUTHORITY OF SELLER'S AGENTS

No agent, employee or representative of the SELLER has any authority to bind the SELLER to any affirmation, representation or warranty concerning the goods sold under this Contract, and unless an affirmation, representation or warranty made by an agent, employee, or representative is specifically included within this written contract, it shall not be enforceable by the BUYER.

NO THIRD-PARTY BENEFICIARIES

This contract is for the sole benefit of BUYER and SELLER and their respective successors and permitted assigns and nothing herein, express or implied, is intended to or shall confer upon any other person or entity any legal or equitable right, benefit, or remedy of any nature whatsoever under or by reason of these Terms and Conditions.

GOVERNING LAW

All matters arising of or relating to the contract or the Terms and Conditions shall be governed by and construed in accordance with the laws of the state in which the project is located.

DISPUTE RESOLUTION

In the event of any dispute between BUYER and SELLER arising out of the terms of the contract and these Terms and Conditions, such dispute shall be decided by arbitration administered by the American Arbitration Association in accordance with the then-prevailing Commercial Arbitration Rules and Mediation Procedures of the American Arbitration Association. BUYER and SELLER mutually agree that any dispute involving claims valued at or above \$1,000,000.00 shall be heard by a panel of three (3) arbitrators. The venue for all arbitration proceedings shall be the State of California. The foregoing agreement to arbitrate shall be specifically enforceable in any court of competent jurisdiction. The award rendered by the arbitrators shall be final and judgment may be entered upon it in accordance with applicable law in any court of competent jurisdiction.

SEVERABILITY

The partial or complete invalidity of any one or more provisions of these Terms and Conditions shall not affect the validity or continuing force and effect of any other provision. If any provision is invalid, in whole or in part, the provision shall be considered reformed to reflect the intent thereof to the greatest extent possible consistent with applicable law.

ASSIGNMENT – DELEGATION

No right or interest in this Contract shall be assigned by the BUYER without the written permission of the SELLER, and no delegation of any obligation owed, or of the performance of any obligation by the BUYER shall be made without the written permission of the SELLER. Any attempted assignment or delegation shall be wholly void and totally ineffective for all purposes unless made in conformity with this paragraph.

NP 3171 HT 3~ 455 | Configuration Summary



Flygt's self-cleaning non-clog N-pumps feature innovative designs and functions that deliver high sustained efficiency and the most reliable operation. This makes them the most reliable choice available for a broad range of wastewater applications for tough applications such as unscreened sewage, wastewater and sludge up to an 8 percent solids concentration. Impeller material available in Hardened cast Iron, Hard Iron and Stainless Steel to fit any wastewater application.

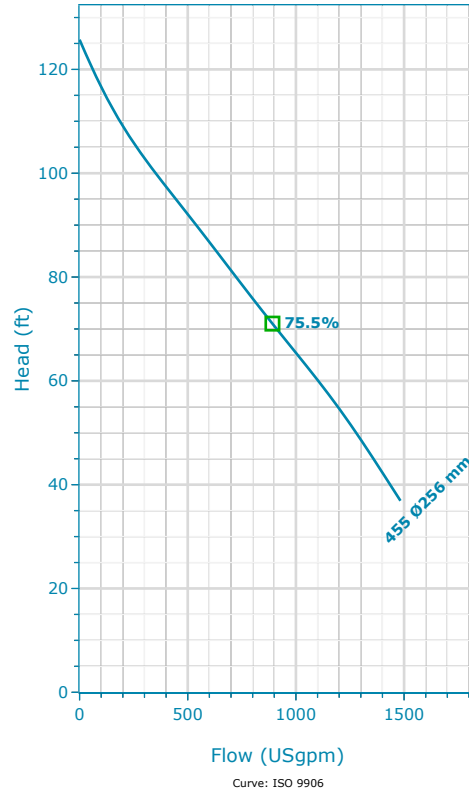

Nominal (mean) data shown. Under- and over-performance from this data should be expected due to standard manufacturing tolerances. Please consult your local Flygt representative for additional performance guarantees.

GENERAL

Explosion Proof	Max. Pumped Media Temp.
Yes	104 °F
Approval	Impeller Diameter
FM	256 mm

MATERIAL AND COATING

Impeller Material
Hard-Iron
Volute Material
Grey Cast Iron

MOTOR

Rated Voltage	Motor Efficiency Class
460 V	Standard
Coupling	Rated Power
D	25 Hp

INSTALLATION

Installation Type
P - Semi-Permanent, Wet

NP 3171 HT 3~ 455 | Product Details

Description

N 3171

The Flygt N-series are equipped with the Flygt invented N-technology with its innovative self-cleaning impeller. Solid objects entering the pump will pass through the impeller between the impeller vanes. If an object gets caught on the leading edge of one of the vanes, it will slide along the backswept shape towards the perimeter of the inlet where it will be guided by a relief groove through the pump housing. This ensures a high sustained total efficiency over time. Due to the mechanical self-cleaning design, a sludge concentration of solids up to 8% can easily be pumped. The pump can easily be installed in either permanently or temporary submerged, or horizontally or vertically dry installations.

Flexible and Modular Design

The modular hydraulic design enables customization of the hydraulics to meet the requirements of many applications.

- Replaceable wear ring in two materials, gray iron or Hard Iron, for different operation conditions
- Hardened gray iron impeller for typical wastewater applications
- Hard-Iron impeller for heavy duty wastewater applications containing abrasive and corrosive content
- Chopper ring intended for tough wastewater applications where cutting is required due to long fibres and solid concentrations up to 10-12%
- Stainless steel impeller for special applications that require duplex stainless steel

Robust and Reliable

- Short shaft overhang reduces shaft deflection and increases seal and bearing life
- Class H Motor designed for submersible use. Heat is concentrated to the stator core for improved cooling properties.
- The Plug-in seal with Active Seal system eliminates the risk associated with incorrect installation and careless handling. All in one unit. Available in Tungsten carbide (WCCR) or Silicone carbide (SiC) depending on pumped media.
- Motor cable SUBCAB® specially developed for submersible use
- Offers flexible cooling systems, e.g. closed-loop cooling system, media cooled or external cooling that allows full motor potential in dry installations.
- Premium brand bearings, greased for life, ensures a minimum of 50 000 hours of duty
- Leakage sensor and motor temperature sensor as standard

The N 3171 is available with the following options:

- ATEX, FM, CSA-approvals
- Premium efficiency motors
- Hard Iron hydraulic design
- Stainless Steel hydraulic design
- Vibration-sensor, extended motor temperature sensors, additional leakage-sensor, current-sensor and pump memory
- Compatible with SmartRun® Wastewater pump controller
- Compatible with MAS 801 monitoring system

Product Features

- State-of-the-art wastewater pump with N-technology
- Sustained high efficiency pumping with energy savings up to 25%
- Flexible and modular design
- Robust and reliable

Construction Materials

Impeller Material	Volute Material	Stator Cover Material
Hard-Iron	Grey Cast Iron	-

Motor

Rated Power	Number Of Phases	Start Current Ratio	Motor Issue
25 Hp	3	6.13	12
Motor Denomination	Rated Motor Speed	Insulation Class	Locked Rotor Code
25-14-4AA	1,755 RPM	H	G
Motor Efficiency Class	Rated Voltage	Approval	Max starts per hour
Standard	460 V	FM	30
Version Code	Rated Current	Total moment of inertia	Power Factor 100%
095	30 A	3.3 ft ² lbf	0.89
Frequency	Start Current	Type of duty	Power Factor 75%
60 Hz	183 A	S1	0.86
Max P2 (1x)	Starting Current, Direct Starting	Stator Variant	Power Factor 50%
24.55 Hp	183 A	1	0.78
Number Of Poles	Starting Current, Star Delta	Motor Module	Efficiency 100%
4	61 A	130	88 %
			Efficiency 75%
			89.5 %
			Efficiency 50%
			89.7 %

NP 3171 HT 3~ 455 | Hydraulic Data & Performance Curve

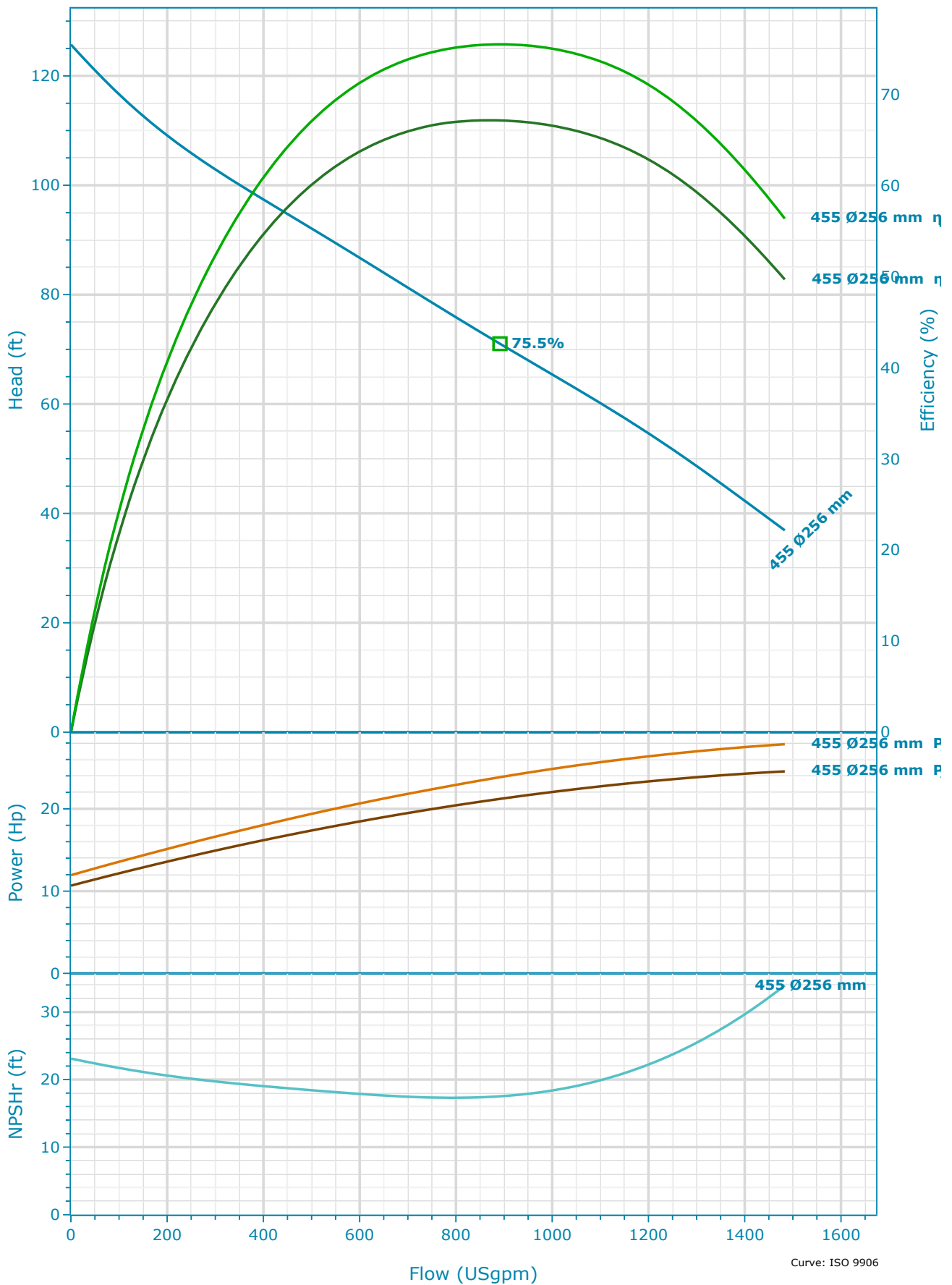

Nominal (mean) data shown. Under- and over-performance from this data should be expected due to standard manufacturing tolerances. Please consult your local Flygt representative for additional performance guarantees.

Selection

Series	Number Of Vanes
N 3000	2
Name	
NP 3171 HT 3~ 455	
Frequency	
60 Hz	
System Type	
Single Pump	
Operating Pumps	
1	
Standby Pumps	
No Standby Pump	
Curve Code	
455	
Impeller Diameter	
256 mm	
Inlet Diameter	
150 mm	
Outlet Diameter	
4 in	

Fluid and Operating Conditions

Fluid Type	Density
Water	62.43 lb/ft ³
Fluid Temperature	Dynamic Viscosity
39.2 °F	1.57 cP
Specific Gravity	Fluid Vapor Pressure
1	0.12 psi
	Atmospheric Pressure
	14.7 psi
	Elevation
	0 ft
	Ambient Temperature
	68 °F
	NPSH Available
	33.68 ft
	Submergence
	0 ft

Design Curve

Rated Speed	BEP Flow
60 Hz	891.41 USgpm
Max Flow	BEP Head
1,483.25 USgpm	71.03 ft
H@QMin	Max P2
125.73 ft	24.55 Hp
H@QMax	
36.9 ft	
BEP	
75.53 %	

Proprietary Notice:
This drawing, print or document and the subject matter disclosed herein are the property of Xylem Water Solutions AB and are not to be disclosed, disseminated or used in any way without our express written permission.



Non-toleranced dimensions see A3221.6
Geometrical and positional tol. see A3222.0



1:20

Pro/ENGINEER Drawing Format A3 Sheet 1 of 1, format rev. 3.0
All dimensions are given in millimeters (mm) unless otherwise stated.

File	Filename	Version created by	Release level	Revision	Iteration
Drawing	7243200	20-Jun-14 08:58:22 AM Kelias, Nermin - Xylem	Released	2	1
ASSEM	7243200	15-May-08 03:28:30 PM svc-PDMLINK WS	Released	0	3

3	Xylem logo on drawing	140068
Rev. No:	Revision	ECN No:

Kit	A	B
722 93 00	691 11 00	83 03 78
722 93 01	691 11 02	83 02 67
722 93 02	691 11 01	83 03 97

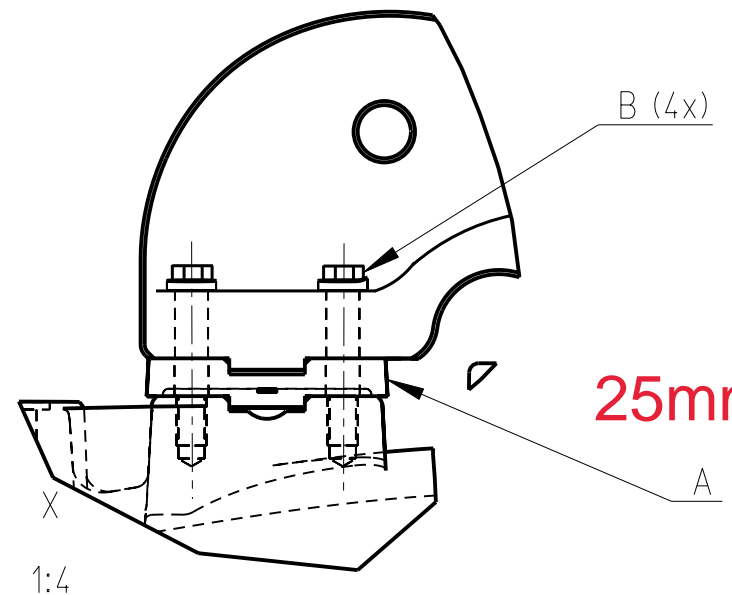

25mm (0.984") Tall

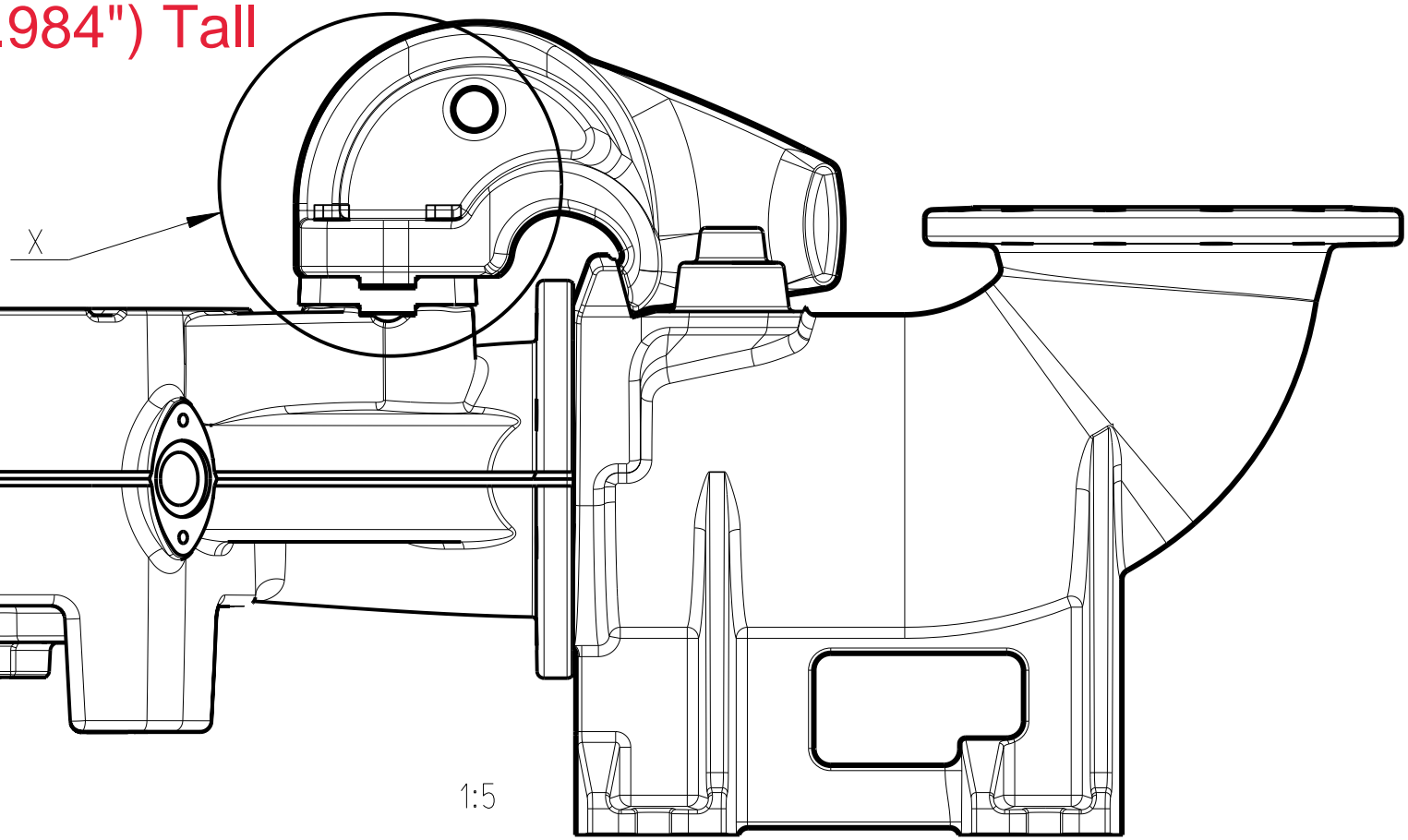

1:5

3

	Denomination Mounting drawing		
	Sheet 1 of 1	Drawing No 724 32 00	Rev 3
	Released		

RESOLUTION NO. 4316

**A RESOLUTION OF THE CITY COUNCIL OF THE CITY OF COALINGA
ADOPTING ITS RECOMMENDATION FOR REVISING THE FISCAL YEAR
2025 / 2026 OPERATING BUDGET**

WHEREAS, the City is required by law to approve a budget prior to the beginning of each fiscal year, and finds it prudent to review the status of the budget throughout the fiscal year; and

WHEREAS, the Financial Services Director and requesting City Department Heads have undertaken a thorough review of the request and account; and

WHEREAS, the City Council has received and considered the Staff recommendations and adjustment to the budget for Fiscal Year 2025-2026, commencing July 1, 2025, and ending June 30, 2026; and

WHEREAS, the purpose of the budget adjustment is to update the community on the financial condition of the City and recommend adjustments to the City's Budget that have been identified subsequent to budget adoption; and

WHEREAS, it is the intention of the City Council to adopt the Staff recommendations and said budget as modified and amended by the City Council of the City of Coalinga as the Financial Amended Budget for the fiscal year 2025-2026.

NOW, THEREFORE, BE IT RESOLVED BY THE CITY COUNCIL OF THE CITY OF COALINGA AS FOLLOWS:

1. That the City Council of the City of Coalinga hereby approves and adopts the Staff recommendations with the following budget adjustment:

Account Number	Account Description	Current Budget	Increase	Decrease	Adjusted Budget
503-000-39500	General Fund-Fund Balance	\$6,630,311		\$35,000	\$6,595,311
503-521-98040	Major Machinery & Equipment	\$60,000	\$35,000		\$95,000
	Total		\$35,000	\$35,000	

2. From and after the adoption date of this resolution the several amounts stated in the Final Annual Budget hereinafter referred to as adopted expenditures shall become and thereafter appropriated to the offices, departments, accounts, objects and purposes stated therein for the fiscal year to which said budget is to apply and said monies are hereby authorized to be expended for the purposes and objects specified in said budget.

3. All resolutions and parts of resolutions in conflict herewith, including, but not necessarily limited to, such resolutions or parts of resolutions relating to compensation, allowances or benefits as may be in conflict herewith, are hereby expressly repealed.

4. This resolution shall take effect immediately upon adoption.

PASSED AND ADOPTED by the City Council of the City of Coalinga at its regular meeting held on **April 2, 2026**, by the following vote:

AYES:

NOES:

ABSTAIN:

ABSENT:

APPROVED:

Nathan Vosburg, Mayor

ATTEST:

Shannon Jensen, City Clerk



Budget Adjustment Form

BA No. 26-021

To: Financial Services Department
From: Public Works
Contact Name: Eric DeLeon

Fiscal Year: FY25/26
Date: 4/2/2026
Resolution No: 4316

Type of Request: (Check one)

Budget Appropriation Transfer Receipt of Unanticipated Revenue

Project previously approved by City Council?

No Yes. Provide Approval Date: 6/18/2025

ACTION

Transfer From	Budget Line	Description	Amount
	503-000-39500	Wastewater Enterprise-Fund Balance	35,000
Total:			35,000

Transfer To	Budget Line	Description	Amount
	503-521-98040	Major Machinery & Equipment	35,000
Total:			35,000

Totals in "Transfer FROM" and "Transfer TO" must match.

Justification of the Transfer (Required)
 Increase one time project amount of (\$35,000) for the replacement of 2 submersible pumps for the Sandalwood Lift Station.

Approvals

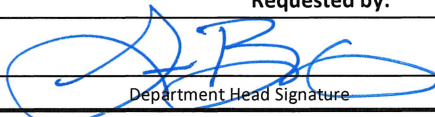
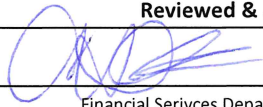
<p>Requested by:</p> <p> Department Head Signature <u>3/20/26</u> Date</p>	<p>Reviewed & Approved by:</p> <p> Financial Services Department <u>3/30/2026</u> Date</p>
---	--

APPROVED by the City Council of the City of Coalinga, State of California,
 this _____ day of _____ 20_____.

ATTEST: _____
 City Clerk

Approved by: _____
 City Manager Signature Date

**STAFF REPORT - CITY COUNCIL/SUCCESSOR AGENCY/PUBLIC FINANCE
AUTHORITY**

Subject: Authorization for the City Manager to Accept Quote for Street Sweeper Repair
Meeting Date: Thursday, April 2, 2026
From: Sean Brewer, City Manager
Prepared by: Jesse Barron, Assistant City Manager

I. RECOMMENDATION:

Authorize the City Manager to accept the quote from Municipal Maintenance Equipment (MME) for street sweeper repair in the amount of \$32,586.51.

II. BACKGROUND:

The gutter broom of the City's primary street sweeper has had multiple failures in operation. The hydraulic system had debris from an unconfirmed source, presumed to be from motor malfunction. MME has attempted isolated repair of the system, however a near full hydraulic system repair/replacement has been needed, as debris has contaminated the entire hydraulic system.

III. DISCUSSION:

This quote is the third, and final, quote received from MME, as the price has escalated as more damage to the hydraulic system has been discovered through testing of the sweeper broom after initial repair has shown further malfunction. MME management has acknowledged the duration of repairs, and the continued cost escalation as unacceptable, and is confident that this authorization will allow for a fully repaired machine to be delivered rapidly.

IV. ALTERNATIVES:

- Authorize the City Manager to accept the repair quote from MME in the amount of \$32,586.51,
- Do Not Authorize the repair. The result will be an inoperable street sweeper without a clear path toward alternative repair.

V. FISCAL IMPACT:

The fiscal impact will be \$32,586.51 to the street sweeping fund. Due to the urgency of an item a budget adjustment resolution was not prepared as of this report however, a budget adjustment will be provided to the City Council at the next meeting in the amount of \$54,686.36 to adjust for the prior maintenance and repair expenses to date.

ATTACHMENTS:

File Name

Description



MME_Sweeper_Quote.pdf

Quote for Sweeper Repair



ESTIMATE

Order Number: 018861
Status: On Hold
Appointment Nbr: FS - FS000018411-2
Order Date: 3/17/2026
Customer ID: C00200

REMIT TO:
 4634 Mayhew Road
 Sacramento, CA 95827
 (916) 922-1101 Fax:(916) 922-1034

13922 Gracebee Ave
 Norwalk, CA 90650
 (714) 528-8770 Fax:(714) 528-8744

4750 Caterpillar Road, Unit D
 Redding, CA 96003
 (530) 243-4856 Fax:(530) 243-1447

1930 W. Winton Avenue Ste 1-2
 Hayward, CA 94545
 (510) 670-0230 Fax:(510) 670-9003

SOLD TO:	SHIP TO:
CITY OF COALINGA P.O. BOX 378 COALINGA CA 93210 United States of America	CITY OF COALINGA 135 EAST SACRAMENTO STREET COALINGA CA 93210 United States of America

Confirm To:

Customer P.O.	Ship VIA	F.O.B.	Terms
	Ground		

CUSTOMER REFERENCE:	METER READINGS START:				DESCRIPTION
Cust. Eq # :	Miles:	22350	Aux Hrs:	2442	A9 GUTTER BROOM STOPS SPINNING WHEN EXTENDED
Contact : ERIC RAMSEY	Hours:	3869	Sweep Hrs:	1807	

Item Number	Unit	Ordered	Shipped	Price	Amount
FIELD LABOR REAR DOOR WILL NOT OPEN	HR	3.00	0.00	199.59	598.77
S-22040 REXROTH DO3 VALVE REPLACES S-61978	EA	1.00	0.00	341.70	341.70
TRVL TRAVEL LABOR	HR	7.00	0.00	199.59	1,397.13
SHOP LABOR RGB SPINNING AND WONT PICK UP	HR	9.25	0.00	181.00	1,674.25
M-HD68 CHEV RANDO HD ISO 68, SELL BY THE GALLON	GAL	6.00	0.00	17.62	105.72
S-64903 MOTOR, G/BROOM REPLACES S-22030 (COMES WITH CASTLE NUT)	EA	1.00	0.00	1,099.23	1,099.23
S-22232 3IN SUCTION STRAINER	EA	1.00	0.00	230.90	230.90
S-25110 RETURN FILTER, HYD. REPLACEMENT, STAUFF SF-6720 FOR S-22034	EA	1.00	0.00	78.43	78.43
M-HD68 CHEV RANDO HD ISO 68, SELL BY THE GALLON	GAL	18.00	0.00	17.62	317.16
S-521093 CYLINDER,BROOM INNER, 2 X 5	EA	1.00	0.00	287.62	287.62
S-5207160 ROD END, 5/8-18 DRILLED & TAP	EA	1.00	0.00	58.00	58.00
S-22542 SPRAY TIP YELLOW, PLASTIC	EA	1.00	0.00	1.54	1.54
SHOP LABOR RIGHT GUTTER BROOM MOTOR REPLACEMENT	HR	3.00	0.00	181.00	543.00
SHOP LABOR HYDRAULIC SYSTEM FLUSH / SERVICE	HR	6.00	0.00	181.00	1,086.00



ESTIMATE

Order Number: 018861
Status: On Hold
Appointment Nbr: FS - FS000018411-2
Order Date: 3/17/2026
Customer ID: C00200

REMIT TO:
 4634 Mayhew Road
 Sacramento, CA 95827
 (916) 922-1101 Fax:(916) 922-1034

13922 Gracebee Ave
 Norwalk, CA 90650
 (714) 528-8770 Fax:(714) 528-8744

4750 Caterpillar Road, Unit D
 Redding, CA 96003
 (530) 243-4856 Fax:(530) 243-1447

1930 W. Winton Avenue Ste 1-2
 Hayward, CA 94545
 (510) 670-0230 Fax:(510) 670-9003

SOLD TO:	SHIP TO:
CITY OF COALINGA P.O. BOX 378 COALINGA CA 93210 United States of America	CITY OF COALINGA 135 EAST SACRAMENTO STREET COALINGA CA 93210 United States of America

Confirm To:

Customer P.O.	Ship VIA	F.O.B.	Terms
	Ground		

CUSTOMER REFERENCE:	METER READINGS START:	DESCRIPTION								
Cust. Eq # : Contact : ERIC RAMSEY	<table style="width: 100%; border-collapse: collapse;"> <tr> <td style="width: 15%;">Miles:</td> <td style="width: 15%;">22350</td> <td style="width: 15%;">Aux Hrs:</td> <td style="width: 15%;">2442</td> </tr> <tr> <td>Hours:</td> <td>3869</td> <td>Sweep Hrs:</td> <td>1807</td> </tr> </table>	Miles:	22350	Aux Hrs:	2442	Hours:	3869	Sweep Hrs:	1807	A9 GUTTER BROOM STOPS SPINNING WHEN EXTENDED
Miles:	22350	Aux Hrs:	2442							
Hours:	3869	Sweep Hrs:	1807							

Item Number	Unit	Ordered	Shipped	Price	Amount
SHOP LABOR REPLACE HYDRAULIC PUMPS	HR	5.00	0.00	181.00	905.00
SHOP LABOR REPLACE D03 MANIFOLD	HR	3.00	0.00	181.00	543.00
SHOP LABOR CLEAN OUT HYDRAULIC SYSTEM AND HOSES	HR	25.00	0.00	181.00	4,525.00
MSC-PART-NSTK REPLACEMENT HYDRAULIC LINES	EA	1.00	0.00	500.00	500.00
SHOP LABOR HYDRAULIC REPAIRS	HR	14.50	0.00	181.00	2,624.50
SHOP SUPPLY FEE SHOP SUPPLIES & CONSUMABLES	EA	1.00	0.00	315.00	315.00
HAZARDOUS WASTE FEE HAZARDOUS WASTE HANDLING & DISPOSAL FEE	EA	1.00	0.00	193.87	193.87
SHOP LABOR HOPPER LIFT CYLINER REPLACEMENT	HR	6.00	0.00	189.14	1,134.84
S-64227 CYLINDER, COUNTERBALANCE, 4X16	EA	2.00	0.00	1,364.80	2,729.60



ESTIMATE

Order Number: 018861
Status: On Hold
Appointment Nbr: FS - FS000018411-2
Order Date: 3/17/2026
Customer ID: C00200

REMIT TO:
 4634 Mayhew Road
 Sacramento, CA 95827
 (916) 922-1101 Fax:(916) 922-1034

13922 Gracebee Ave
 Norwalk, CA 90650
 (714) 528-8770 Fax:(714) 528-8744

4750 Caterpillar Road, Unit D
 Redding, CA 96003
 (530) 243-4856 Fax:(530) 243-1447

1930 W. Winton Avenue Ste 1-2
 Hayward, CA 94545
 (510) 670-0230 Fax:(510) 670-9003

SOLD TO:	SHIP TO:
CITY OF COALINGA P.O. BOX 378 COALINGA CA 93210 United States of America	CITY OF COALINGA 135 EAST SACRAMENTO STREET COALINGA CA 93210 United States of America

Confirm To:

Customer P.O.	Ship VIA	F.O.B.	Terms
	Ground		

CUSTOMER REFERENCE:	METER READINGS START:	DESCRIPTION
Cust. Eq # :	Miles: 22350 Aux Hrs: 2442	A9 GUTTER BROOM STOPS SPINNING WHEN EXTENDED
Contact : ERIC RAMSEY	Hours: 3869 Sweep Hrs: 1807	

Item Number	Unit	Ordered	Shipped	Price	Amount
SHOP LABOR HOPPER DOOR CYLINDER REPLACEMENTS	HR	3.00	0.00	189.14	567.42
S-67782 CYLINDER, DOOR LATCH, 1.5 X 3	EA	1.00	0.00	1,379.82	1,379.82
S-65290 2" x 17" DUMP CYLINDER 235TE	EA	2.00	0.00	1,926.91	3,853.82
SHOP LABOR TILT CYLINDER REPLACEMENT	HR	1.00	0.00	189.14	189.14
MSC-PART-NSTK HYDRAULIC FITTINGS	EA	1.00	0.00	38.44	38.44
S-521093 CYLINDER,BROOM INNER, 2 X 5	EA	1.00	0.00	299.13	299.13
FREIGHT FREIGHT & TARIFFS ADDITIONAL	EA	1.00	0.00	0.00	0.00
MSC-PART-NSTK PARTS DISCOUNT	EA	1.00	0.00	-3,500.00	-3,500.00

PLEASE NOTE: FREIGHT IS NOT INCLUDED IN THIS ESTIMATE
ESTIMATE VALID FOR 30 DAYS

Labor Total: 15,788.05
Parts Total: 16,798.46

Subtotal: 32,586.51
Less Discount: 0.00
Freight: 0.00
Sales Tax: 1,490.26

Order Total (USD): 34,076.77

**STAFF REPORT - CITY COUNCIL/SUCCESSOR AGENCY/PUBLIC FINANCE
AUTHORITY**

Subject: Authorization to Issue Request for Qualifications (RFQ) for Public Information Consulting Services
Meeting Date: Thursday, April 2, 2026
From: Sean Brewer, City Manager
Prepared by: Sean Brewer, City Manager

I. RECOMMENDATION:

Staff recommends that the City Council:

- Authorize the City Manager to issue a Request for Qualifications (RFQ) for Public Information Consulting Services; and
- Authorize the City Manager to evaluate responses and return to the City Council with a recommended consultant and professional services agreement for approval.

II. BACKGROUND:

The City of Coalinga regularly communicates with the public regarding municipal services, infrastructure projects, fiscal conditions, and community initiatives. As part of these efforts, the City occasionally requires specialized professional support to ensure that information is communicated clearly, effectively, and in compliance with applicable legal requirements.

The City is currently evaluating various citywide informational needs, including potential future discussions related to municipal services, fiscal sustainability, and possible revenue measures. To support these efforts, staff has prepared a Request for Qualifications (RFQ) to solicit qualified firms with expertise in municipal public information and communications.

The RFQ is intended to establish a pool of qualified consultants capable of assisting the City in delivering objective, factual, and legally compliant public information.

III. DISCUSSION:

The proposed RFQ seeks qualified firms with demonstrated experience working with California municipalities, particularly in the areas of:

- Public information strategy and outreach
- Community engagement and stakeholder communication
- Development of informational materials (fact sheets, FAQs, presentations, etc.)
- Fiscal and municipal service communication
- Public opinion research (optional, as directed)
- Compliance with laws governing public agency communications

The selected consultant(s) may assist the City with:

- Developing a comprehensive public information and outreach plan

- Preparing clear and accessible informational materials for residents
- Supporting community engagement efforts, including workshops and presentations
- Providing objective information related to City services and fiscal conditions
- Assisting, if directed, with informational materials related to potential revenue measures

All services performed will be strictly informational in nature and must comply with applicable legal requirements, including restrictions on the use of public resources for advocacy.

The RFQ also outlines anticipated deliverables such as informational materials, outreach plans, presentations, and optional survey or polling reports. The contract term is anticipated to be up to 12 months, with options for extension based on City needs.

Issuing this RFQ does not commit the City to any specific project or ballot measure. Rather, it allows the City to identify qualified professionals who can support future informational efforts as directed by the City Council.

IV. ALTERNATIVES:

The City Council may:

- Decline to authorize issuance of the RFQ and direct staff to explore alternative approaches; or
- Provide additional direction or modifications to the RFQ prior to issuance.

V. FISCAL IMPACT:

There is no immediate fiscal impact associated with issuing the RFQ. Any future contract will be brought back to the City Council for approval and will include a not-to-exceed amount. Funding for services, if approved, will be identified within the appropriate budget or funding source at that time.

ATTACHMENTS:

File Name	Description
 Final_RFQ_Public_Information_Services.pdf	Final RFQ Public Information Services



CITY OF COALINGA

The Sunny Side of the Valley

**REQUEST FOR QUALIFICATIONS
FOR
PUBLIC INFORMATION SERVICES**

Prepared By:

Sean Brewer, City Manager
City of Coalinga
155 W. Durian
Coalinga CA 93210

Deadline for Submissions: April 24, 2026 at 5:00 p.m.

REQUEST FOR QUALIFICATIONS

INTRODUCTION AND PURPOSE:

The City of Coalinga is seeking proposals from qualified public information consulting firms with experience working with California municipalities to assist the City with legally compliant public information efforts related to potential municipal revenue measures and other citywide informational initiatives.

The purpose of this engagement is to support the City in providing clear, objective, and legally compliant information to the community regarding municipal services, fiscal conditions, and potential funding measures that may be considered by the City Council.

All work performed under this contract must strictly comply with applicable laws governing public agency communications, including restrictions on the use of public resources for advocacy.

The consultant will assist the City in developing factual, transparent, and accessible informational materials to ensure residents are informed about City services, fiscal conditions, and potential policy considerations.

Engagement of a consultant does not commit the City to placing a measure on the ballot. Any work performed will be informational in nature and subject to direction from the City Manager and City Council.

BACKGROUND AND SETTING:

The City of Coalinga regularly communicates information to the public regarding City services, programs, infrastructure projects, community initiatives, and other matters of public interest. As part of these efforts, the City periodically requires professional public information and communications support to assist with the preparation of clear, accurate, and legally compliant informational materials for the community.

Public information services may support a variety of City initiatives, including community engagement, economic development, public safety programs, infrastructure and capital improvement projects, City Council policy discussions, and citywide informational items related to municipal services and finances. In certain instances, the City may also seek assistance preparing objective informational materials related to potential revenue measures or other policy considerations being evaluated by the City Council.

These public information efforts may involve the preparation of informational content and communication materials used across multiple platforms, including but not limited to the City website, social media channels, printed informational materials, community presentations, surveys, reports, press releases, and other public-facing communications. All work must be conducted in compliance with applicable laws governing public agency communications and the use of public resources for informational purposes.

SCOPE OF SERVICES:

The selected consultant may be asked to provide some or all of the following services.

Public Information Strategy and Planning

The consultant shall assist the City in developing a public information strategy designed to communicate objective information regarding City services, fiscal conditions, and potential revenue measures.

Services may include:

- Development of a public information and outreach plan.
- Identification of key informational topics and messaging themes.
- Preparation of communication timelines aligned with Council direction and statutory deadlines.
- Coordination with City staff to ensure consistency with existing communication efforts.
- Guidance on compliance with applicable laws governing public agency communications.

Fiscal and Revenue Measure Information Support

If directed by the City Council, the consultant may assist the City with preparation of informational materials related to potential revenue measures.

Services may include:

- Preparation of objective fiscal analyses explaining City revenues, expenditures, and service needs.
- Development of informational content explaining how potential revenue measures would function.
- Preparation of clear explanations of fiscal impacts and service implications.
- Assistance with development of legally compliant informational language regarding ballot measures.
- Coordination with the City Attorney to ensure legal compliance of all materials.

Community Outreach and Public Engagement

The consultant may assist the City in designing and facilitating public engagement opportunities intended to inform residents about City services, fiscal conditions, and policy considerations.

Services may include:

- Planning and facilitation of community informational meetings or workshops.
- Development of informational presentations for City Council meetings and public forums.
- Stakeholder outreach and engagement strategies.
- Preparation of informational materials for distribution to residents and businesses.
- Assistance with public meeting facilitation and documentation of feedback.

Informational Materials and Communication Tools

The consultant may develop a variety of informational materials designed to clearly communicate City information to the public.

Deliverables may include:

- Informational fact sheets and summaries.
- Frequently Asked Questions (FAQ) documents.
- Infographics and data visualizations.
- Website content or digital informational materials.
- Presentation materials for community meetings and City Council briefings.
- Mailers or printed informational materials, if directed.

All materials must be objective, factual, and legally compliant.

Public Opinion Research (Optional)

If directed by the City Council, the consultant may conduct research to better understand community awareness and perspectives regarding City services, fiscal conditions, or potential policy measures.

Services may include:

- Community surveys.
- Polling or statistical research.
- Focus groups or stakeholder interviews.
- Analysis of community feedback.
- Preparation of summary reports and findings.

All research conducted must comply with applicable legal requirements.

Legal Compliance Coordination

The consultant shall work closely with the City Manager and City Attorney to ensure that all communications, materials, and activities comply with applicable state laws governing the use of public resources for informational purposes.

The consultant shall:

- Submit draft materials for legal review when required.
- Follow guidance provided by the City Attorney regarding compliance requirements.
- Ensure informational materials remain neutral and factual in nature.

Reporting and Project Management

The consultant shall provide project management and regular communication with City staff.

Responsibilities include:

- Coordination with the City Manager and designated staff
- Regular progress updates
- Preparation of periodic reports summarizing work performed
- Attendance at meetings as requested by the City

DELIVERABLES

Deliverables may include, but are not limited to:

- Public information and outreach plan.
- Fiscal informational materials.
- Community outreach materials.
- Presentation materials for public meetings and Council briefings.
- Informational fact sheets and FAQs.
- Survey or polling reports (if conducted).
- Summary reports documenting outreach activities and findings.
- Short-form video content: Many residents now get their info from 30-60 second clips.
- Interactive digital tools: Such as "Budget Simulators" where residents can see the impact of revenue changes in real-time.
- Multi-lingual outreach: If Coalinga has a significant Spanish-speaking population, explicitly requiring bilingual capabilities will ensure you get firms with "inclusive" expertise.

CONSULTANT QUALIFICATIONS

Firms responding to the RFQ should demonstrate:

- Experience working with California municipalities.
- Experience with municipal revenue measure informational campaigns.
- Knowledge of legal requirements related to public agency communications.
- Experience conducting public opinion research and community engagement.
- Ability to develop clear, accessible informational materials for the public.

Preference may be given to firms with demonstrated experience assisting cities with informational outreach related to local revenue measures.

CONTRACT STRUCTURE

The City anticipates entering into a professional services agreement with the selected consultant.

The agreement may include:

- A not-to-exceed contract amount
- Defined task orders or work phases
- Hourly billing rates for personnel
- Optional services that may be authorized by the City as needed

TERMS OF SERVICE

The anticipated term of the contract will be up to 12 months, with the option to extend if authorized by the City Council.

SUBMITTAL REQUIREMENTS:

One (1) electronic copy via email of the statement of qualifications must be received no later than **5:00 p.m. on April 24, 2026**. Late proposals will not be considered. Proposals should be addressed to:

Sean Brewer, City Manager
sbrewer@coalinga.com
155 W. Durian Ave
Coalinga, CA 93210

EVALUATION:

Proposals will be evaluated based on:

- Relevant experience and qualifications
- Quality and suitability of work samples
- Responsiveness and availability
- Proposed fee structure
- Overall best value to the City

The City reserves the right to select and/or reject any and all SOQs submitted. It is the City's intent to negotiate a final Scope of Work and Fee for Service with the top selected firm based on the criteria above.

SELECTION PROCESS:

Proposals Due: April 24, 2026 by 5:00 p.m.

Consultant Selection/Interviews (if determined): April 27-29, 2026

City Council Approval of Professional Services Agreement May 7, 2026

***Council presentations may be required at the request of the City Council prior to final section.**

PROFESSIONAL SERVICES AGREEMENT:

Prior to the start of work, the selected consultant will be required to execute a Professional Services Agreement (PSA) with the City. The awardee will also be required to obtain or provide proof of a City of Coalinga business licenses.

QUESTIONS:

Please submit all questions in writing to Sean Brewer at sbrewer@coalinga.com.

STAFF REPORT - CITY COUNCIL/SUCCESSOR AGENCY/PUBLIC FINANCE AUTHORITY

Subject: Strategic Priorities Overview and FY 2026–2027 Budget Direction
Meeting Date: Thursday, April 2, 2026
From: Sean Brewer, City Manager
Prepared by: Sean Brewer, City Manager

I. RECOMMENDATION:

Receive an overview of the City’s adopted strategic priorities and provide direction to staff regarding Council priorities to guide development of the Fiscal Year 2026–2027 budget.

II. BACKGROUND:

On March 29, 2025, the City Council participated in a facilitated goal-setting session to establish strategic priorities for the City. The purpose of that session was to align the Council and executive leadership on key focus areas, strengthen working relationships, and identify priority initiatives intended to enhance quality of life, public safety, infrastructure, and economic development within the community.

The outcome of the session was the identification of six primary strategic priority areas:

- Infrastructure and City Improvements
- Community Engagement and Events
- Public Safety and Emergency Preparedness
- Technology and Administrative Modernization
- Employee and Organizational Development
- Housing and Economic Development

Since that time, staff has been actively working to implement projects and initiatives aligned with these priorities and has incorporated them into ongoing operations, capital planning, and policy development efforts.

Additionally, since the adoption of these priorities, the composition of the City Council has changed, and newly appointed Councilmembers were not part of the original strategic planning session. As such, it is appropriate to provide a summary of the adopted framework and confirm alignment moving forward.

III. DISCUSSION:

This agenda item is intended to serve as a high-level review of the City’s current strategic direction and to facilitate Council discussion as staff begins preparation of the Fiscal Year 2026–2027 budget.

The discussion will focus on the following key areas:

- Confirmation that the existing strategic priority areas continue to reflect Council’s direction
- Identification of any adjustments or areas of increased emphasis
- Consideration of whether the City should focus on completing existing initiatives or expanding into new efforts

- Opportunity for Councilmembers to introduce new ideas or initiatives for consideration

The City currently has a significant number of projects and initiatives underway across multiple departments. As part of this discussion, staff is seeking policy-level direction to ensure that available resources, including funding and staffing capacity, are aligned with Council's highest priorities.

This discussion is not intended to revisit or recreate the entire strategic plan, but rather to reaffirm and refine the City's direction to ensure continued progress and alignment with Council expectations.

IV. ALTERNATIVES:

- Provide direction as recommended
- Provide alternative direction regarding priorities for FY 2026–2027
- Continue the item to a future meeting for additional discussion

V. FISCAL IMPACT:

There is no immediate fiscal impact associated with this item. Direction provided by the City Council will inform the development of the Fiscal Year 2026–2027 budget, including the allocation of available financial resources and staff capacity.

ATTACHMENTS:

File Name	Description
Envision_2025_Summary.pdf	Envision Projects List Summary 2025

ENVISION 2025 – CITY OF COALINGA

Infrastructure & City Improvements

- **Citywide Upgrades:**
 - Upgrade City Access Control Systems
 - Rehabilitate City Hall & Police Department (flooring, paint, lighting)
 - Replace charging stations in back parking lot.
- **Landscaping & City Facility Projects:**
 - Modernize Exterior of Fire Department (Landscaping, Signage, Paint).
 - Complete Landscaping at City parking lot.
 - Re-Pave City Hall/Police Department Back Parking Lot.
 - Complete Animal Shelter.
 - Explore the Feasibility of a New Veterans Hall.
- **Transportation & Parking:**
 - Complete Phase 1 of the Center Median Project.
 - Phase 1 Valley Gutter Project.
 - Slurry/Cape Seal Project Phase 2.
 - Update Curb painting near schools.
- **Utility & Safety Enhancements:**
 - New Fueling station for the airport.
 - Repair All Lighting at the Airport.
 - Backup generator connections for Sewer Lift stations.
 - Install the remaining backflow enclosures.

- **Reservoir & Water Projects:**

- Complete Derrick Reservoir Project
- Complete Water Plant and Wastewater Plant Solar Projects.
- Update Water Treatment Plant Standard Operations Procedures.
- Completion of ADA Transition Plan Update.
- Increase Wastewater Treatment Plant Land Discharge Area.

2. Community Engagement & Events

- **Major Events:**

- Council/Staff Team Building Event.
- National Night Out (Aug 5, 2025).
- Coalinga Airshow (Sep 27, 2025).
- Annual Employee Appreciation Party (Employee Awards).

- **Public Amenities:**

- Complete Ramsey Splash Park (2026)
- Banner decorations on light poles.
- Holiday lighting for City Hall, Fire Department, and Archway signage.

- **Outdoor Spaces:**

- Begin design of the outdoor food court.
- Install sail shades at the dog park.

3. Public Safety & Emergency Preparedness

- **Emergency Readiness:**

- Implement Civic Ready for emergency preparedness.
- Install Fire Department generator.
- Purchase a command trailer for PD.

- **Ambulance & Fire Services:**

- Increase ambulance rates (unchanged since 2014).
- Improvements to the Fire Department training center.
- Remodel Fire Department Bathroom.
- Sponsor Medic School & Academy.
- Feasibility Plan for Increased Presence of the Fire Department at the Coalinga Airport including Ancillary Services (ie. CAL Fire, Sky Life, Ect)

- **Policy & Regulation Updates:**

- Update Animal Control Ordinance.
- Address commercial vehicle parking standards.
- Clean City Initiative: Update Property Maintenance Regulations to Ensure Property Owner Accountability in an Effort to Beautify and Clean City.

4. Technology & Administrative Modernization

- **Digital & Process Improvements:**

- Implement NeoGov (Human Resources automation)
- Complete implementation of “One Meeting” agenda software.
- Implementation of AI for Building Plan Checks.

- **Online Services:**

- Enable credit card payments for all services.
- Implement virtual pay with the bank.

- **Website Modernization:**

- Start website redesign efforts.
- Chatbot Integration (AI) into Website.
- Public Records Request Efficiency (NextRequest).

5. Employee & Organizational Development

- **Appreciation & Recognition Programs:**
 - Launch personnel appreciation programs (Employee of the Month, longevity awards, ect.).
- **Employee Benefits & Education:**
 - Expand education on retirement, medical benefits, and mental/physical wellness programs.
- **Finance & Policy Updates:**
 - Decentralize finance functions.
 - Update reserve policy.
 - Update CAL Card policies.
 - Update Purchasing policy, travel, and cash handling procedures.

6. Housing & Economic Development

- **Affordable Housing:**
 - Build 3 ADU units.